



Power Partners Solar

200 Newton Bridge Road, Athens, GA 30607 (706)548-3121

"Skyline" Closed Loop System 5

Models: "200152C80EX", "200153C80EX" and "200154C80EX"

SRCC OG300 Rated Systems

INSTALLATION MANUAL

September 2007



The solar energy system described by this manual, when properly installed and maintained meets or exceeds the minimum standards established by the Solar Rating and Certification Corporation (SRCC) and the collectors meet or exceed SRCC OG100 and FSEC minimum standards. This certification does not imply endorsement or warranty of this product by SRCC.

CONGRATULATIONS!

Thank you! You have just purchased the most attractive and easiest to install active solar water heater made! We have worked on every detail to assure you that the Power Partners solar water heating system will completely satisfy you in its very high level of performance and dependability.

Table of Contents

Tools and Materials	1.0
Systems, Components, Options and Diagram.....	2.0
Specifications and Schematics.....	2.1
Antifreeze Safety Data.....	2.1.1
Components included with system.....	2.1.2
Important Notes.....	2.2
Collector Location, Orientation and Tilt.....	3.0
Overview of the Basic Installation Steps.....	4.0
Assembling the Collector (Split Kits Only)	5.0
Collector Installation.....	6.0
Determining the Best Pipe Run.....	7.0
Making Line Connections.....	8.0
Control Component Details.....	9.0
Tank Connections.....	10.0
Charging the Solar Loop.....	11.0
Questions and Answers.....	12.0
Certifications.....	12.1

**PLEASE CALL Power Partners WITH QUESTIONS
706-548-3121 or 1-800-545-3121**

WE WELCOME YOUR COMMENTS! We have worked to make Power Partners installation instructions easy and complete. We are always looking to make them better and **welcome** your comments and suggestions!

PLEASE READ ENTIRE MANUAL BEFORE STARTING INSTALLATION

System 5 can be installed in straightforward situations by two experienced people in less than 6 hours. With no experience, the installation will probably take 2 people 8 to 12 hours, with added complications, like a longer pipe run or two stories, taking longer.

SAFETY FIRST!! See section 2.2

This Installation Manual assumes good technical experience and ability.

NOTE: The collector has some sharp metal edges and corners. Please use caution when handling the collector.

1.0.

Tools and Materials

ITEMS SUPPLIED BY POWER PARTNERS:

- Collectors, with mounting rails, Ell brackets, U Center brackets and Solar Feed and Return line adapters.
- Coin Vent, Pressure Relief Valve, and copper adaptor.
- PV Panel with mounting brackets and hardware.
- Storage Tank Heat Exchanger brass connections with Expansion tank, Pressure Gauge, "Floating Ball" Check Valve, Charging valves, and 2 Temperature Gauges.
- 12 Volt Pump and connections.
- 50' 1/2" outside diameter copper solar loop lines.
- Solar loop installation parts kit including miscellaneous parts, fittings, screws, nuts, bolts, etc.,
- All hardware, two roof boots, 6' high temperature insulation.
- Mixing Valve.
- Installation Manual, Operation and Maintenance Manual and Stickers.

TOOLS AND MATERIALS NEEDED:

Overview: Everyday homeowner tools are all that are needed to assemble and install the Skyline solar loop.

Tools and Materials Needed:

- For assembling a split kit or Skyline split kit model collector: Pop Rivet Gun, 2 large adjustable wrenches and/or wrench set (to secure collector absorber brass unions and compression fittings and to attach collector sections together using joiner strip).
- Min 18" Pipe Wrench (best to have 2).
- Quality Pipe Sealant (to seal face of brass union ends).
- Ladder(s) (for roof and for access to attic as needed).

- Tape measure, marking pencil, crayon or chalk (to mark rafters and holes on roof)
- Chalk for marking the roof and Snap Line.
- 1 1/2" inch wood bit for roof penetrations (for feed and return lines through roof).
- 7/16" socket with ratchet and 6" extension. (A powerful drill with adapter is desirable for quickly driving lags).
- 1/4" nut driver on high speed drill (to drive 1/4" self tapping screws into collector).
- Caulking gun with quality Polyurethane or Silicone roofing caulk (to fill lag holes and seal flashing to prevent leaks).
- 3/4" or 1/2" wall, 7/8" ID (about 12 feet) and 5/8" ID high temperature open cell pipe insulation for inside piping.
- Charging Pump and 2 buckets, 3 laundry hoses to charge system with Polypropylene Glycol (usually 2 gallons 100%).

2.0.

The following Systems, Components and Options are Wholly or Partly Covered in this Manual

Note: This manual covers 20-01 collector installation. The 10-01 collectors are OG100 approved for use with this system and can be substituted 2 for 1.

System 5

Complete 20 Square Foot (1.86 m²), 20" x 12' (.508 m x 3.66 m), Solar Panels with mounting kit and Rails, **12 Volt PV Powered Circulator + Complete Rheem Double Wall Heat Exchanger Tank Connections.** These advanced 12V PV powered systems have matched PV Panels and Pumps for best operation. 2 collector system includes EISid Circulator with 20 Watt PV Panel, A larger 12V Electronic Circulator and 30 Watt PV Panel is used for 3 or 4 collectors, with 25' of wire, 50' - 1/2" OD Copper connecting line, all line connections, Collector Air Vent and Pressure Relief Valve, 2 Temperature Gauges, Mixing Valve, Install Kit, full instructions, Owners Manual. Includes Expansion Tank and all Connections. 81V080HE1 **TANK NOT SUPPLIED.**

Two Collectors, Three Collectors, Four Collectors (double for 10-01 collectors):

=====

Tilt Kit (option) Tilts collectors approximately 18 degrees from existing roof angle. Other angles available on request. Tilt kits are used when a better winter angle is desired on a low pitch roof or to "re-orientate" panels to face south by running the panels up and down an East or West facing roof. See Special Instructions.

Single Panel: Collector kit with 3 Modified 24" rails with 6" legs and hardware:
(Option Code /#TK01)

Double panels: Collector kit 3 - 4' 1" x 1" Aluminum Rails with 12" legs and hardware:
(Option Code /#TK02)

Triple panels: Collector kit 3 - 6' 1" x 2" Alum. Rails with 24" legs and hardware:
(Option Code /#TK03)

Standard Color (Default): Musket Brown (C101)

Free Optional Color: Dove/Old Town (Medium) Gray (C109) - Note: This is a no cost option.

Optional Colors Include: Colonial (light) Gray (CO102), Tahoe Blue (CO103), Colonial Red (CO104), Forest green (CO105), White (CO106), Buckskin Brown (CO107), Beaver (medium) Brown (CO108), C.B. (medium) Blue (CO110), Spanish Green (CO111), Storm/Slate (dark) Gray (CO112), Royal Brown (CO113), Ivory (CO114), Sea Blue (CO115), Leaf Green (CO116), Pebblestone Clay (CO117), Woodbeige (CO118), Peach (great on many light orange tile roofs) (CO119), Almond (CO120), Black (CO121), Adobe Tan (CO121), Classic Cream (CO122), Bronze (CO123), Heritage Cream (CO124), Marine Green (CO125).

Components (for individual purchase):

MVWA, Watts Mixing Valve:

QF34, Quad Flow Diverter

TR50, 50 foot roll of 3/8" ID, 1/2" OD soft copper tubing with 2 compression unions

ES10, El Sid 10 Watt 12V Circulator:

HC18, March 809 18 Watt 12V Circulator

PV10, 10 Watt 12V Panel with Mounting Hardware:

PV20, 20 Watt 12V Panel with Mounting Hardware:

PV20, 30 Watt 12V Panel with Mounting Hardware:

PR15, 150 Pound Pressure Relief Valve:

CV01, Floating Ball Check Valve:

H180, 180 F High Temperature snap switch

Skyline System 5 OG300 Single Tank Installation



Models: 200152C80EX, 200153C80EX, 200154C80EX,

SkyLine Collectors: 40, 60, or 80 S/F

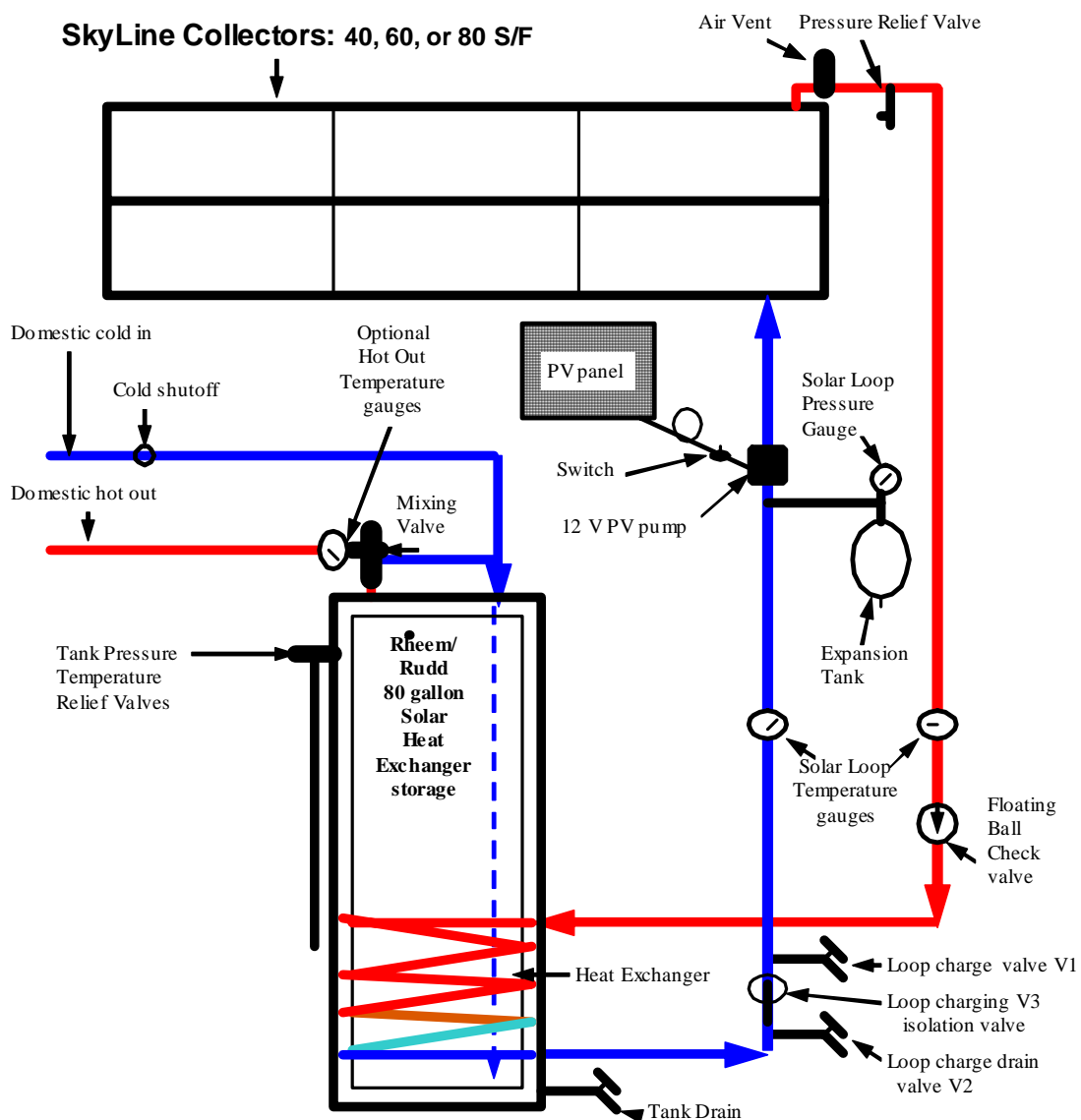

SkyLine System 5 OG300 2 Tank Installation

Note: This system is SRRCC certified only- Not FSEC certified.

Models: 200152C80EX2TG, 3TG, 2TE and 3TE

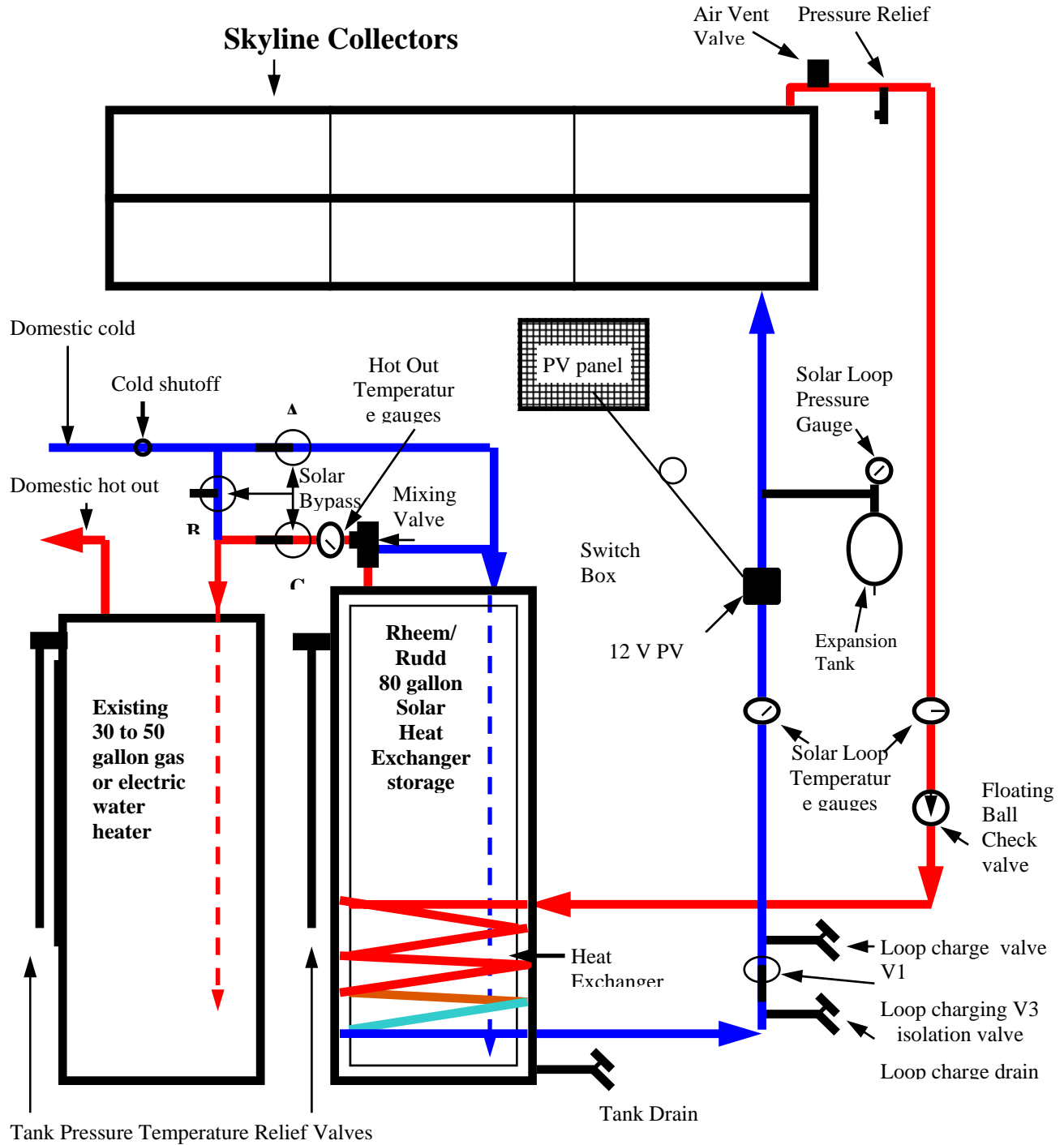

SRCC Required Solar Bypass Valves

Normal Solar Operation: A, and C are Open and B is Closed

Solar Tank bypass: A, and C are Closed and B is Open

2.1.

System 5 OG300 Solar Water Heater Specifications

COLLECTOR (Panel)

Trim & Frame Materials:	Finished 27 mil Aluminum Trim and Frame = Total 54 mil (1.37 mm).
Absorber Material:	"Clear Crystal" coated - all Copper with unions.
Glazing:	.236" (6.0 mm) Twinwall Polycarbonate UV Treated
Dimension / Weight:	200 -144.3"x 20."x 3" 38 lb (3.67 m x 0.51 m x 0.076 m 17.24 Kg) 18.4 Net s/f (1.71 m ²)
Fluid Capacity:	.3/10 gallon
Recommended Flow Rates:	.20 to .35 GPM (0.946 to 1.324 L/min)
Maximum Working Pressure:	150 PSI (10.21 atm).
Maximum Stagnation Temp:	250 °F (121.11 °C).
Heat Transfer Fluid:	Potable water or Propylene glycol
Standard Components:	Mounting rails, mounting brackets, tech screws and lags
Color:	Musket Brown (CI01 - default color) or Dove/Old Town Gray (C109) + optional colors

PV (Photovoltaic) POWERED CIRCULATOR

PV Panel:	20 or 30 Watt, 12volt DC
Circulator:	12 Volt - "El Sid", March or equal.

FREEZE PROTECTION

Type: Closed Loop Glycol with Storage Tank Heat Exchanger.

The Power Partners closed loop Propylene Glycol Antifreeze heat exchange system's collector as well as feed and return lines will not be damaged by (ambient) hard freeze temperatures as low as -54 degrees F below zero with a 60/40 mixture of propylene glycol/water. The solar storage tank must be kept in an area above 32 degrees F.

CONNECTING LINES, INSULATION (standard)

Tubing	1/2" (12.7 mm) OD copper - 50' (15.24 m)
Insulation	(6' (1.83 m) supplied): 1/2" (12.7 mm) ID 1/2" (12.7 mm) or 3/4" (19.05 mm) wall

TUBING CONNECTION METHODS (standard)

Type: Brass Union, Compression, (Brass Fittings for Heat Exchanger)

STORAGE TANK - Rheem / Rudd / Richmond Model Number: 81V080HE1

(Not Supplied) 80 Gallon Tank with In Tank Double Wall Heat Exchanger.

Fluid Used:	Propylene Glycol (Sierra)
Components Supplied:	Expansion Tank, one floating ball check valve, Temperature Gauge, fill, drain, and pressure relief valves.

CONTROL

Type: 12 Volt Circulator with Switch, which automatically regulates circulator operation.

Although we will make every effort to give notice, Specifications and prices subject to change without notice.

2.1.1.

Antifreeze Safety Data - Sierra Antifreeze-Coolant

FLUID HANDLING, SAFETY AND FIRST AID:

- 1. Store fluid in tightly closed and properly vented containers, away from heat, sparks or open flame.**
- 2. Dispose of any aqueous waste at permitted landfill sites only.**
- 3. Chemical splash goggles or full face shield must be worn when possible eye contact exists.**
- 4. Ingestion: Give pint of luke warm water or induce vomiting if large quantity is ingested.**
- 5. EMERGENCY PHONE: 1-800-424-9300 (CHEMTREC)**

Freezing point:	-28° F (50/50 mixture)
Flash Point:	700° F (100% glycol 0)
Boiling point:	256° F (50/50 mixture @ 15 PSI)
Boiling point:	365° F (100% glycol @ atmospheric pressure)
Appearance:	Green
Specific Gravity:	1.04
Vapor Density:	2.6

2.1.2

Components Included with the SolarRoofs Type 5

Please Note: Power Partners has improved its system and some pictures will not be visually accurate but show all the components included. Most copper fittings have been replaced with Brass. More visually accurate pictures will be included in their sections.

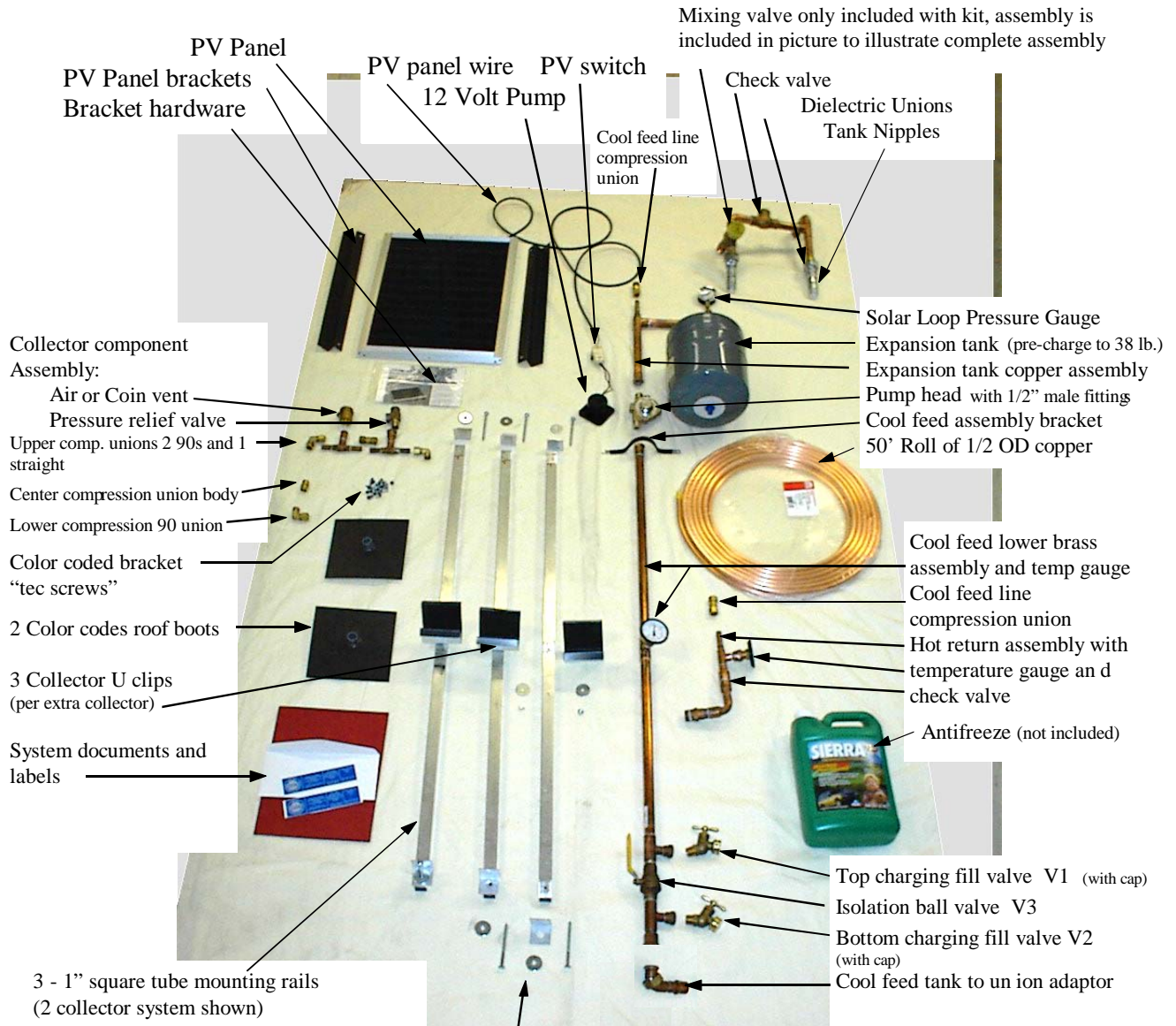

2.2

IMPORTANT NOTES:

CHECK WITH YOUR LOCAL BUILDING DEPARTMENT FOR CODE COMPLIANCE FOR THE INSTALLATION OF YOUR SOLAR WATER HEATING SYSTEM.

SAFETY FIRST!!

USE CAUTION!!! Do not attempt to self-install without help if you have **ANY** back or physical limitations!!!

GENERAL WARNINGS:

This manual assumes that the installer has good mechanical experience, can confidently use hand tools, building materials and adhere to safe building and installation practices.

Power Partners does not assume responsibility for any loss, or injury directly or indirectly, associated with the installation of this system.

Do not install this system alone without someone knowing where you are and what you are doing at all times.

In all cases where a firewall (drywall) is penetrated, it is important to seal the hole. A good general rule is to always fill in and seal around all holes made for solar lines to prevent heat loss and to maintain fire stops.

Properly support all piping according to local code. As a rule, support copper pipes every 6'.

Power Partners systems are easy to install; however, problems resulting from a failure to correctly install the system according to the following instructions and to maintain it according to the operation and maintenance manual are not covered by the warranty.

3.0

COLLECTOR LOCATION, ORIENTATION AND TILT

Your solar water system will be providing savings for your family for decades to come. Because the sun rises in the east, crosses over the horizon on the south and sets in the west, you want your collector to face as much to the south as possible. **Your system needs the most sun it can get!**

As long as the collector angle (known as tilt) is at least 14 degrees up from horizontal, (a typical roof angle is 22 to 28 degrees) additional tilt usually has little effect on total year round performance. **The exception** is in areas with very sunny winters (as in most areas of Colorado) where a higher angle, (facing the collector more directly into the winter sun) can help year round performance.

In most areas with **heavy winter overcast**, a solar collector's orientation on a low pitched roof can face anywhere from 45 degrees east to west

of south without losing more than 8% of the energy it would have produced if it were facing directly south. At 90 degrees east to west of south the loss is closer to 20%.

Exceptions include easterly facing systems in areas with a lot of morning fog and clear afternoons where south facing or west facing would be much better. The opposite can be true if sunny mornings are very often followed by rainy afternoons.

Take these facts into consideration when locating your collector and consult with us if you have any questions.

ROOF CONDITION:

The condition of your roof should be good although one of the features of Skyline system is that removing and replacing the collector is relatively easy for re-roofing.

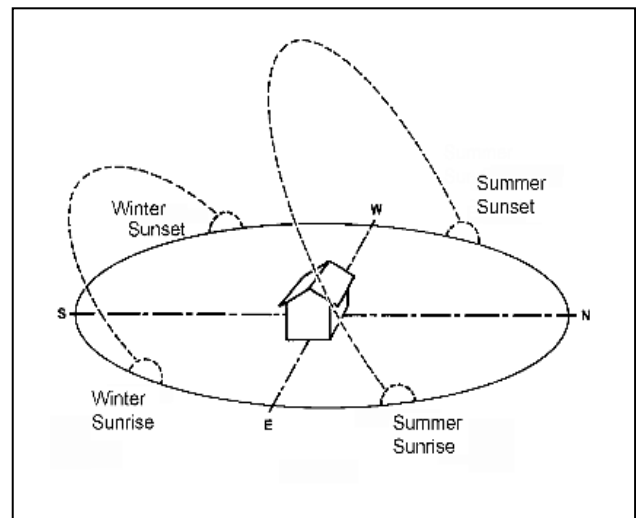
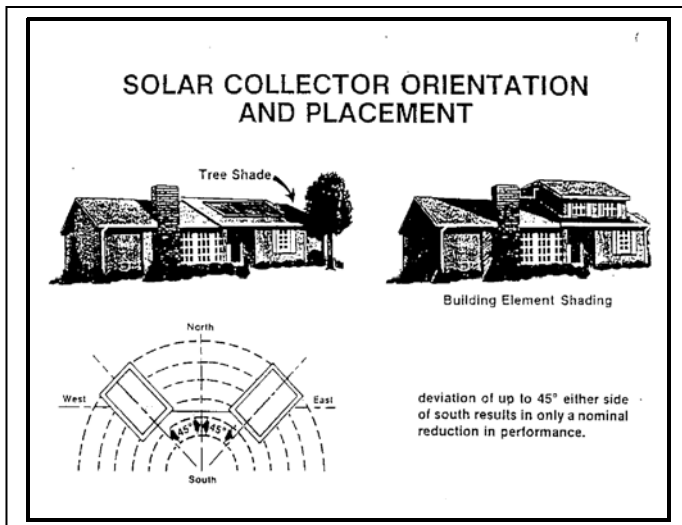

4.0

OVERVIEW - THE BASIC INSTALLATION STEPS:

THE BASIC INSTALLATION STEPS (3 to 8 hours required to install, depending on situation and experience)

1. Unpack collector, for split kits, assemble the collector left and right sections into one unit as per pictures and instructions. Note: not shown, the 24' collector has a center mullion that needs to be attached to the collector after joining the unions. Two 6' sheets of Polycarbonate glazing go into each side of it.

2. Collector placement on roof located, rafters located and marked, end mounting rails with brackets lagged and sealed into rafters, collector placed into mounting rail brackets, center mounting rail and brackets placed, lagged and sealed into rafter, mounting rail brackets screwed into collector.

3. Collector compression unions connecting air vent, pressure relief valve and components installed, two 1 1/2" holes drilled into roof for hot feed and cool return lines. Shingles trimmed and "Roof Boots"

installed under shingles and into holes. PV panel installed.

4. Collector cool feed (bottom compression union) and hot return lines (top compression union) installed through roof boots to tank area. PV wire connected and run to water heater area. Insulation partly installed before tubing connections are made. PV panel installed.

5. Water Heater Element turned off, water drained, lower drain removed, Rheem 80 gallon Heat Exchanger tank installed with Mixing Valve. Water lines connected including installation of the Mixing valve. Brass Solar lines with valves connected to heat exchanger top and bottom. Pump, pressure gauge and expansion tank installed. Collector cool feed (from pump) and hot return lines connected by compression union.

6. Water heater refilled, solar loop purged of air, pump wired to PV panel. Glycol loop filled, finish insulating lines, Fill Tank, Element turned back on.

5.0

ASSEMBLING THE COLECTOR (See Supplemental "Split Kit" Addendum)

6.0

COLLECTOR INSTALLATION

BE SECURE AND USE CARE!!!

Good procedure suggests that you always secure your ladder to the gutter so it does not slip. Place blocks in the gutter so the weight of the ladder does not crush the gutter. Protect the surface of the gutter with a cloth to prevent marks.

WALKING ON THE ROOF:

Use soft sole shoes. Walk in the center of

the shingle to prevent knocking off the brittle ends of the shingles. This care will keep the roof in good condition and prevent dangerous ball bearing like gravel and tar balls from making the roof treacherous.

Know how to walk on your roof if it is a special type such as Tile or Metal, ask your roofer or ask us. For example, stepping in the center of most Tile roof shingles will

break them.

Always put your weight on the last two (overlapping) inches of the tile and away from the side that overlaps the next tile (to avoid chipping off the delicate vertical overlap strip).

On some shingles, such as "Fire-Free", or shake, more damage is done stepping on the end than in stepping on the center. Shake roofs are usually easy to walk on but use care on shake roofs to not crack or break off brittle shakes. **Shake roofs, as well as most roofs, can be treacherous when wet.**

As the 20-01 collector is 12' long, it is important to place the line connection end so it is the shortest distance from the storage tank.

The collector can be flipped either way to be closest to your storage area. Remember that the feed line from the pump goes to the bottom collector connection and the hot return goes to the top collector connection as shown in the diagrams.

On an average, low pitch single story roof, one able person can safely install the Skyline collector. **Do not install this system alone. Be sure someone knows where you are and what you are doing at all times.**

The 20-01 collector is 12 feet long, only 20 inches wide and under 38 pounds, making it an ideal size and weight for one person to lean against the roof or gutter, go up the ladder and simply pick up the collector and pull up onto the roof.

Collector installation Components:

Note 10-01 collectors will have 2 sets of collector brackets instead of 3

Roof Kit contains:

Mounting Ells and washers,
3.5 or 4" Lags,
Center U Brackets for 2 or
more collectors,
Color coded Tec Screws for
securing Ell brackets and U
brackets to collector,
Low profile Roof Boots.



PV Parts Bag contains PV
switch Brackets and
hardware. See 9.0,
Control Component
Detail.

Plumbing Kit:

50' of 1/2" OD Copper,
Pressure Relief,
Coin (air) vent,
Soldered adaptor,
Compression fittings,
1 Compression union
body per extra
collector,
2 compression unions
to connect tubing to
tank.

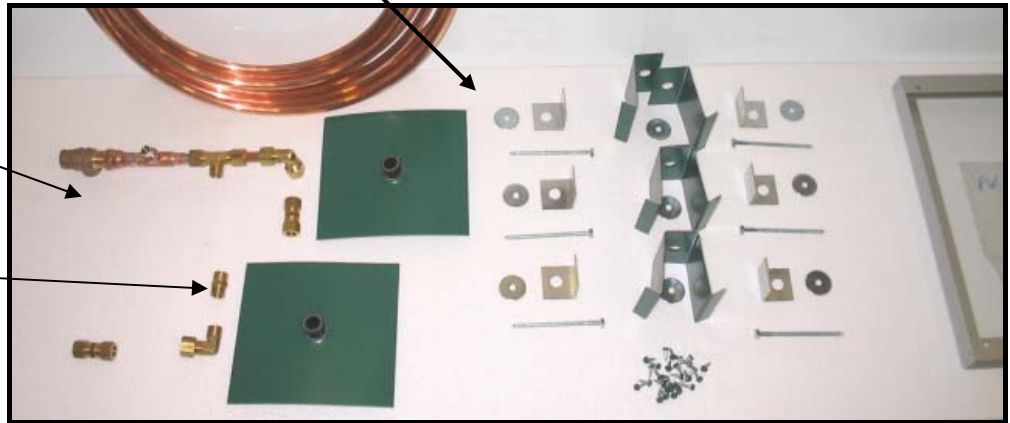

Important Instructions Regarding Installing Compression Unions

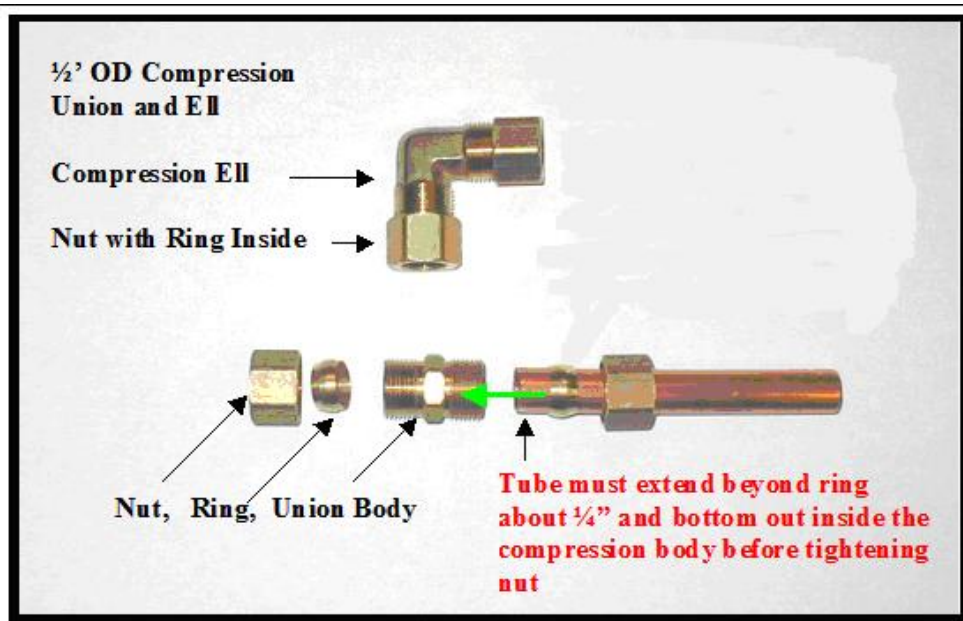

Collectors mount horizontally and Collector Mounting Rails go as shown below.

Two Collector 20-01 Top View (10-01 collectors use 2 rails about 1' in from the ends)

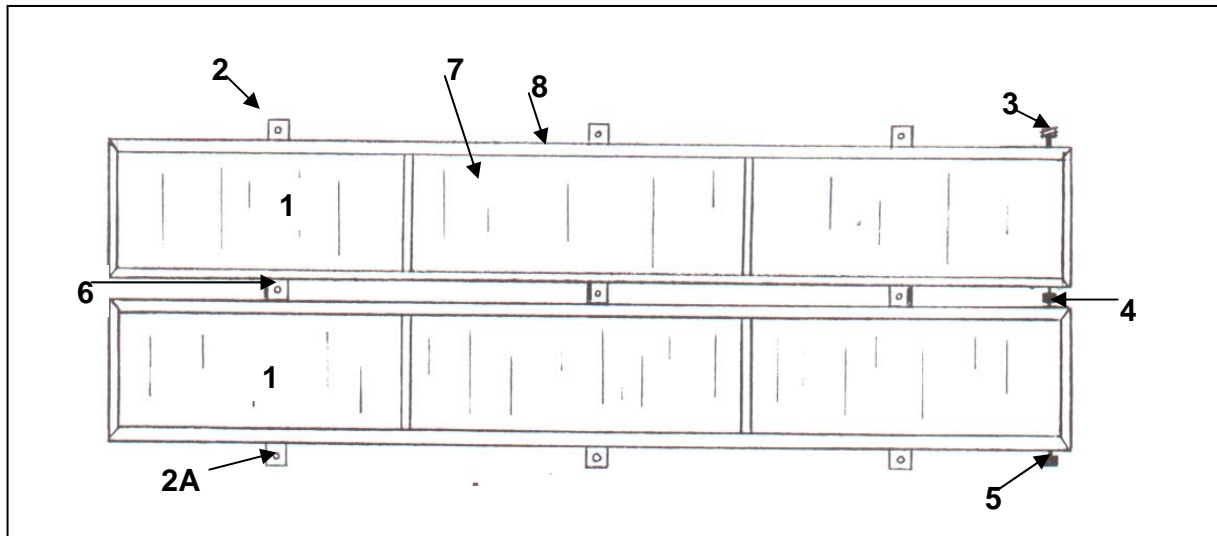

The Diagram above is a top view of two collectors installed together showing

1. Two 20" x 12' Collectors mounted with connections to the right.
2. The Mounting Rails with Mounting Brackets (3 rails and 6 Mounting Brackets plus 3 Quick Connect Clips (QCC) per additional collector set (6.), 3 two panel rails, 6 Mounting Brackets and 3 QCCs shown in this diagram).
- 2a. Mounting Rail Lag holes top and bottom.
3. The "Hot Out" Collector connection going to the storage tank.
4. The between Collector connection.
5. The "Cold In" Collector connection from the storage tank.
6. The Quick Connect Clip bolts to the mounting rail here with the tabs overlapping the top of the collector.
7. Collector Glazing (Polycarbonate).
8. Collector trim sections.

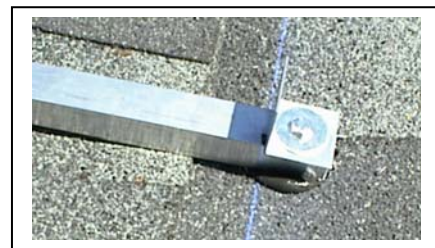

Above: Allowing from 14" to 2' for collector overhang, find and mark Rafters for the Three Collector Rails, (shown in this picture are 3 rails for 3 collectors) Use a chalk line to get the 3 rails even at the bottom. Get the center rail as close to center between the end rails as possible. Using a hammer to "Sound Out" the rafters usually finds the rafters. If not, use a feeler bit (long small drill) to drill through the roof from the inside, just beside the rafter. **Be sure to squeeze caulk into all holes to seal them!**

Pre-Drill the bottom holes for the 2 end rails (which will be about 8' apart – you can use the lag itself to "pre drill"), squeeze Caulk into Lag Hole, Place end mounting rail with mounting bracket and washer over hole (above left). Drive Lags into holes but do not tighten. Carefully place the center rail along the chalk line, repeat the procedure for the end rails. Install the upper lags using the same procedure. Note: One and two collector systems have lags at the top and bottom of the rails. Three and four collectors use a center lag at the center of the end rails only. Other Quick connect clips use a carriage bolt.

2001 Side View

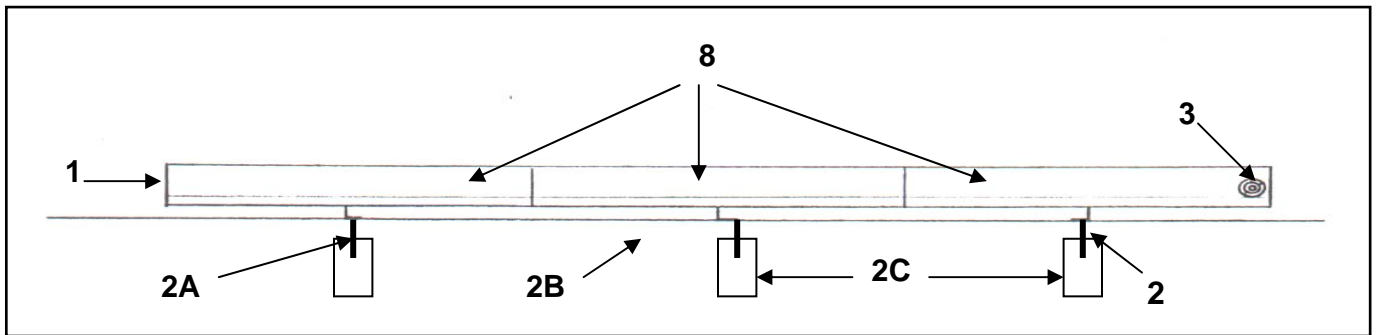

The above Diagram shows a side view of the Collector installed on the roof and shows:
(Refer to Color Pictures for Details of Ell Brackets)

- | | |
|--|---|
| 1. Side view of a Collector. | 2C. Roof Rafter. |
| 2. Mounting Rails (3 per 20-01 collector). | 3. Collector feed or return connection. |
| 2A. Mounting Rail Lag. | 8. Collector Trim. |
| 2B. Roof sheathing. | |

LAGS AND RAFTERS:

For maximum strength, you want your mounting rail (2) lags (2A) to go into rafters. After locating the best area for the collector, "sound out" the roof for the rafters with a hammer and mark the rafter centers with chalk. On thick roofs, such as shake, you may need to drill a small hole from the underside of the roof next to the rafter to locate it from the roof and use measurements from thereon. On thin composition roofs, a good stud finder can be very helpful in finding the center of the studs.

It is best to "run the lag into the roof once, remove it, then fill the hole with caulk and run the lag with washer back in and tighten. Some installers like to pre-drill the hole with a smaller bit than the lag to prevent cracking shake shingles.

Alternate Collector Mounting Methods

The Easy Way (avoids having to locate rafters):

In areas with average wind conditions, (Highest winds up to 75 MPH) the light weight of the collector allows you to use "Hollow Wall Expanding Anchors."

If using this method, be sure to use the ¼" size bolt. Drill a ½" hole through the sheathing to allow for the thickness of the anchor. Place the anchor in the hole, pull the nut end up, using the supplied ¼" bolt, until it is tight, but do not over tighten!

Hollow Wall Expanding Anchor



Note: For high Wind areas, use a lag into a "Spanner Board" between the rafters. For extra strength the spanner boards can be toe-nailed into the rafters. Another option is to use a "J" hook around a rafter but location options are limited with this method.

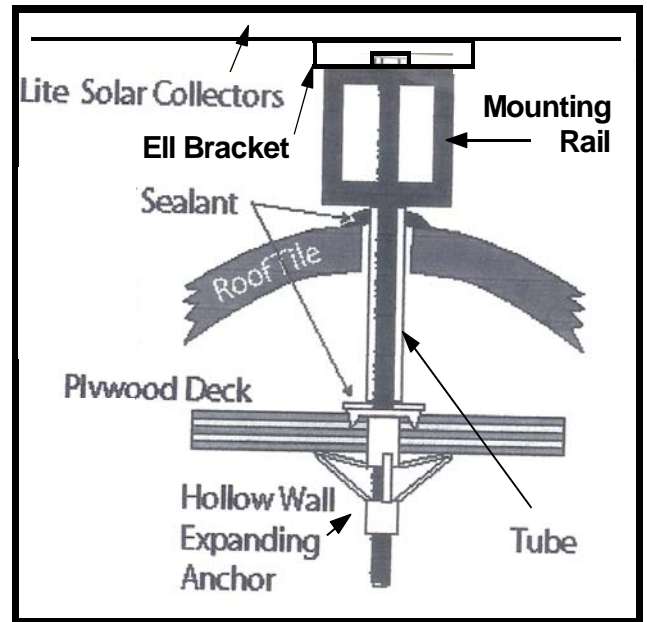
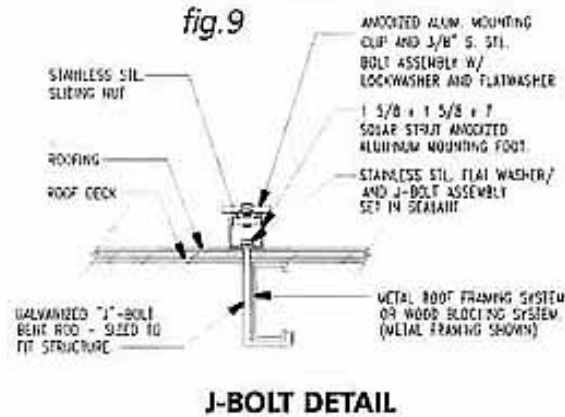

Tile Roof Installations

Expanding Anchor Tile Roof Installations: (be prepared to get longer 1/4" / 20 bolts)

NOTE: Correct placement of the collectors on tile is very important. Look for the best locations for the rails so the collector will not bottom out or "Rock." Do not drill through 2 tiles and do not drill to close to the edge to prevent cracking.

Holes drilled about 3" - 4" in from the end of the tile are usually the best locations. This allows the hole to be only through one tile and closer to the stronger overlap. Relocate holes in the rail as needed. The collector can go over lag heads in the rail.

The expanding anchor can make tile roof installations much easier. On flat tile, a spanner tube usually is not needed, just be sure to not over tighten the anchor bolt.

On barrel tile, make a spanner tube out of 1/2" conduit, copper tube or other sturdy material; drill a hole just large enough to fit the tube through the tile, with it sticking up about 1/4" when seated on the Anchor base.

Drill a 1/2" hole through the sheathing (if you happen to hit a rafter, use a lag). Lift up the end of the tile and place the anchor in the hole and tighten to seat it securely in place.

Standing Seam Installations:

Consider using the excellent S-5 Clamps.

<http://www.dynamicfastener.com/main.htm>



GETTING THE COLLECTOR ONTO THE ROOF

Use wisdom, when pulling collectors up onto the roof, have the collector at a good angle to the roof (out at the bottom). Protecting the gutter with a heavy cloth may be a good idea. Do not lean over the edge of the roof at all, simply pull and leverage the collector up onto the roof. The assembled collector is very sturdy, but avoid "twisting" it.

If the edge of the roof is over 10 feet from the ground, the bottom of the collector may be placed on a sturdy object or

someone may be needed to boost the collector up to you.

On two story houses we strongly recommend two people for safety.

A sling can be made with sturdy rope going all the way around the bottom of the collector with shorter pieces going around the collector to secure the rope in place. Be sure to secure it very well and always have a secure safety rope you can grab onto. Have the second person push the collector up the ladder while it is pulled at the top.



Protect Edge of Roof with a Tarp and Lean Collector Against Roof



Keeping your body weight over the Roof, pull the Collector Up



Move Up the Roof as you Pull the Collector Up a Foot or so at a Time.



Balance the Collector in the Center and Carry to Installation Area.



A NOTE ON MAKING TUBE CONNECTIONS:

The tube connections top and bottom shown in top view as 3 & 5 are made at the top and bottom of ONE end of the collector. The connections can be at either end of the collector simply by placing the collector end left or right. When two or more collectors are used they also connect at the same end (4).

Make sure you do not have a rafter directly under the collector feed as the feed hole is 1 and ½ inches below and in from the end of the collector.

MOUNTING RAIL AND MOUNTING BRACKET INSTALLATION STARTING WITH SINGLE COLLECTOR:

A single 20-01 collector is attached to the roof by three mounting rails and 6 mounting EII brackets.



Above: Top EII Bracket in place and ready for top collector to be installed.



Position the EII bracket **between the trim and frame** so it is **CENTERED** over the **Lag hole**. Install the collector onto the rails with the mounting bracket tab **UNDER** the trim and **BETWEEN** the frame. The small bend at the bottom of the trim makes inserting the mounting bracket easy. Be sure to press the collector all the way down on the mounting rail and secure with two 1/4" color coded self tap screws evenly just above the small bend in the trim. **Be sure to catch the tab with both screws!**

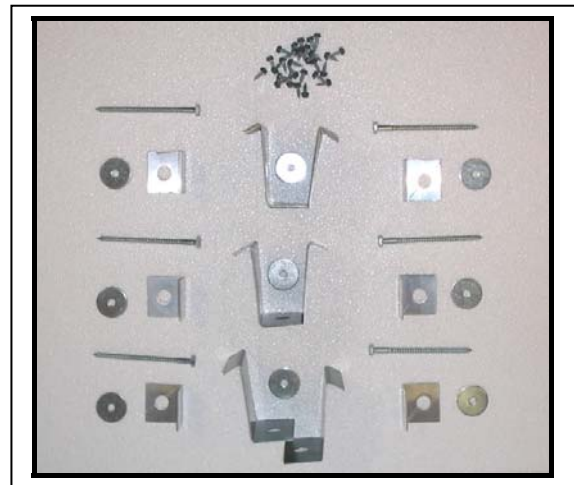

Above: Complete Collector mounting kit for 2 collectors. 3 EII brackets bottom, three U bracket sets per additional collector and 3 EII brackets top.

Note: 10-01 collector has 2 sets of each.

Two, Three and Four Panel Mounting Rails and Tilt Kit (two collector maximum per tilt kit):

For installing two to four collectors or when two collectors are installed on the optional tilt rack, a special Quick Mount clip (6) is used between the collectors to firmly hold them onto the mounting rail. All holes are predrilled. With tilt kit sets of 1/4" nuts, bolts and washers are supplied as needed in addition to lags to bolt the tilt kit together and secure the angle brackets.

The Quick Mount clip allows mounting of two collectors on the two panel-mounting rail or the heavy-duty tilt rail without needing to screw a mounting bracket tab into the side of the collector.

The U shaped clip with outward tabs that go over the edge of the two collectors is secured with a bolt in the center. In high wind areas, it is recommended that the clips be Tec screwed into the frame through the glazing with 2 screws.

Notes on Two, Three and Four Collector Flush Mount Installations:

Place the first collector in place with mounting bracket tabs inserted for final assembly. Tighten down the lags. Place three Quick Mount clips in place over their rail lag hole locations. Partially install the lags to hold the clips loosely in place. **(You will need an extension to your lag driver to get between the collectors)**. Slip the next collector under the clips, connect the compression unions (4) so alignment is assured and then tighten down the lags. Repeat until all collectors are installed.



Quick Connect Clips (QCC's) are supplied in one or two pieces with the single piece shown. Shown, in the top right above, laid out as to how they will go and individually to the left next to the rail with carriage bolt. **It is easiest to remove the nut before placing the collectors on the rails.**

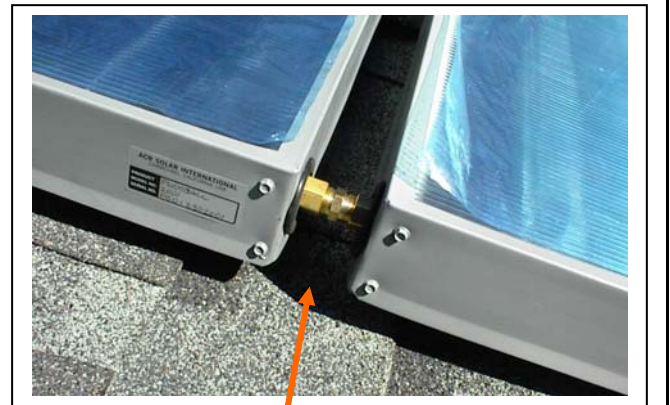
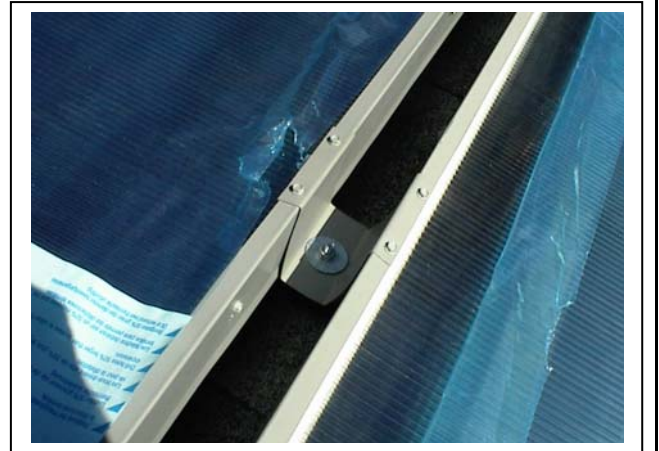

Being sure the trim is pushed in, secure the U bracket at the top on both sides with 2 tec screws going through the bracket, trim and glazing. This makes a very strong connection.

FLASHING IN UNDER SHINGLES

For Tile and other roofs, consult with the Factory.

For Composition and Cedar Shake Installation:

ACRSI supplies two special roof "Flashings" which are used to make a waterproof seal for the solar collector feed and return lines. These flashings easily slip under a composition or shake shingle with minimum cutting.

The tubing hole is large enough for the 1/2" od copper pipe to easily slip through and the small space left can be easily sealed with caulk and further covered with insulation. The base of the flashing can flex and be moved in different directions.

The 6" aluminum base is usually large enough to make a watertight seal and can easily be flashed over by a larger aluminum sheet when needed. It is recommended that a 1 1/2" hole be drilled for the tubing hole

"Roof Boot" Flashing and Waterproofing Details

The 2 aluminum flashings supplied with the system are easily installed but require careful alignment to assure a good fit. It is recommended that up to a 1/2" hole be drilled to give "working room" when installing the roof boot. **Spacers are included with flush kits to make boot installation easier. Pre-fit roof connections prior to drilling (see Section 8, top and bottom connections).**

NOTE: Sound out your roof to be sure no rafters are under where holes will need to be drilled!

Preposition the roof boot where it will go when the pipes are connected to the compression 90 in its final "out" position. Mark the center of the hole, remove the fitting and place out of the way. Using a 1 1/2" hole saw or paddle bit, drill the hole. Carefully pry up the shingle and slip the Roof Boot under the shingle so water will freely flow over the roof boot.

If needed, add aluminum flashing to assure a watertight installation (especially needed with Cedar Shake). Caulk the sides as needed and it is good to put two roofing nails in the bottom of the boot to secure it AFTER the pipes are installed and fully secured.

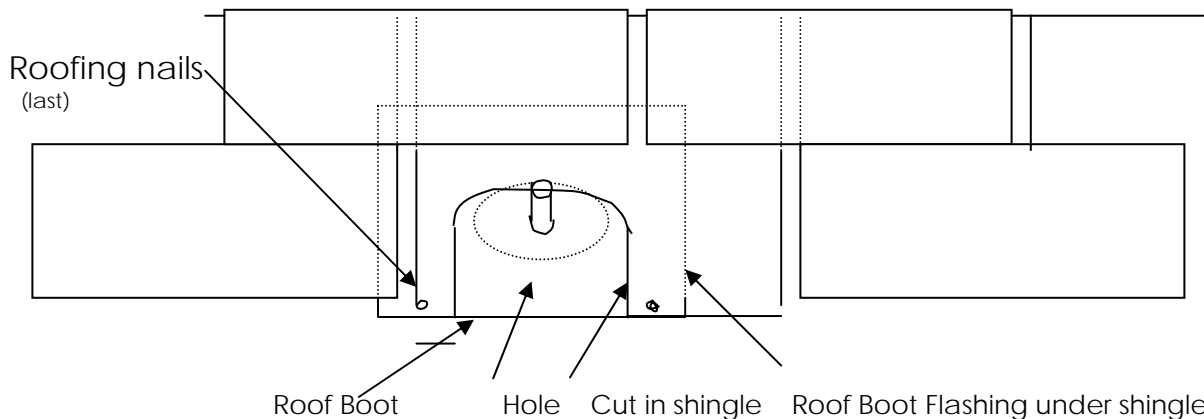

Note that Roof Boot is UNDER the shingles at the top and most of the sides so water flows over the top. The shingle is cut down from where the hole is drilled.



Use a "lifting Tool" with smooth edges to go under and lift the shingle without cutting it. Lift shingles before installing collectors.



Drill a 1 1/2" hole 1 1/2" in and centered 2" below the edge of the collector. Slip flashing under shingles.



Properly placed, the feed line is right above the flashing tube hole. The edge of the collector is 1 1/2" above the lower edge of the rails.

SC01 Stacked Array Installation Kit

Loosely assemble your kit, per the following pictures, to locate the exact location of your roof penetrations and then follow the flashing and roof boot installation instructions.

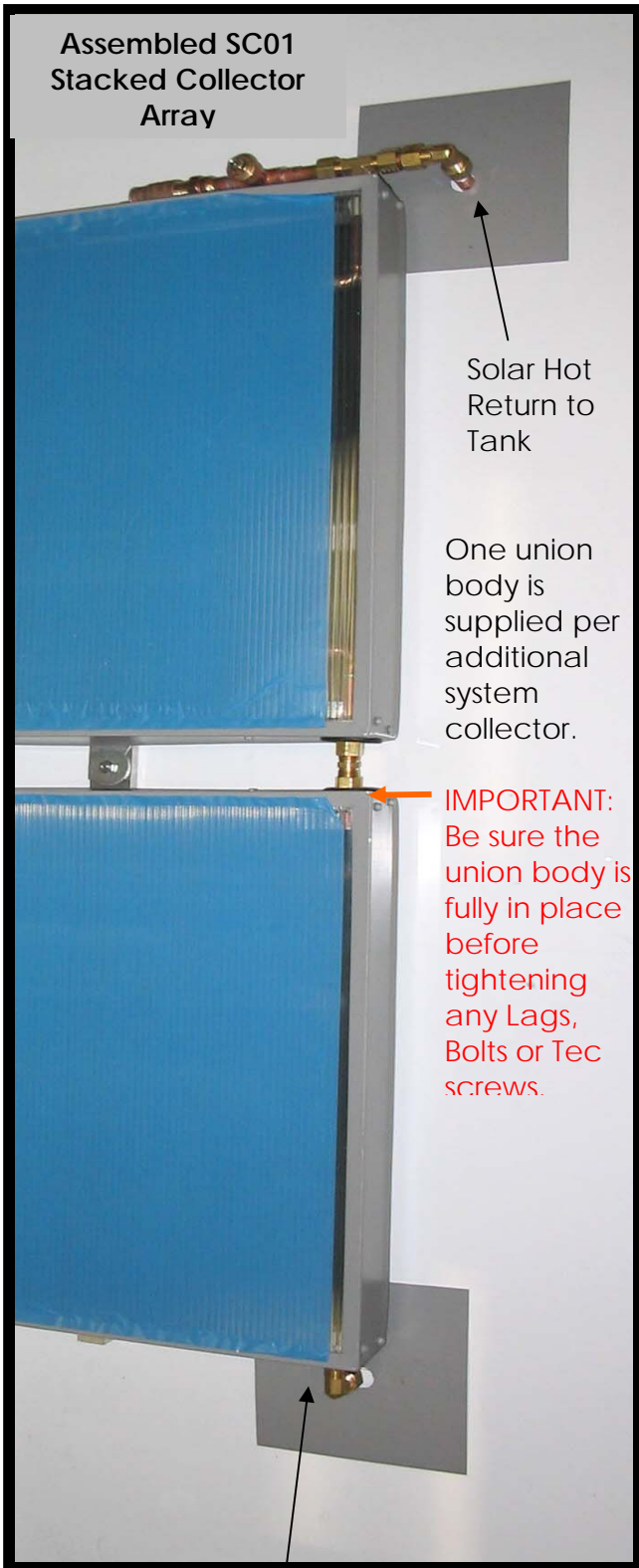

IMPORTANT: Be sure the union body is fully in place before tightening any Lags, Bolts or Tec screws.

Feed Ell from Pump

SC01 - Stacked Collector Array Installation Kit

Pre-soldered adaptor for Pressure Relief Valve and Coin Vent

Coin Vent (Normally Shut Tight)

2" stick of 1/2" OD copper

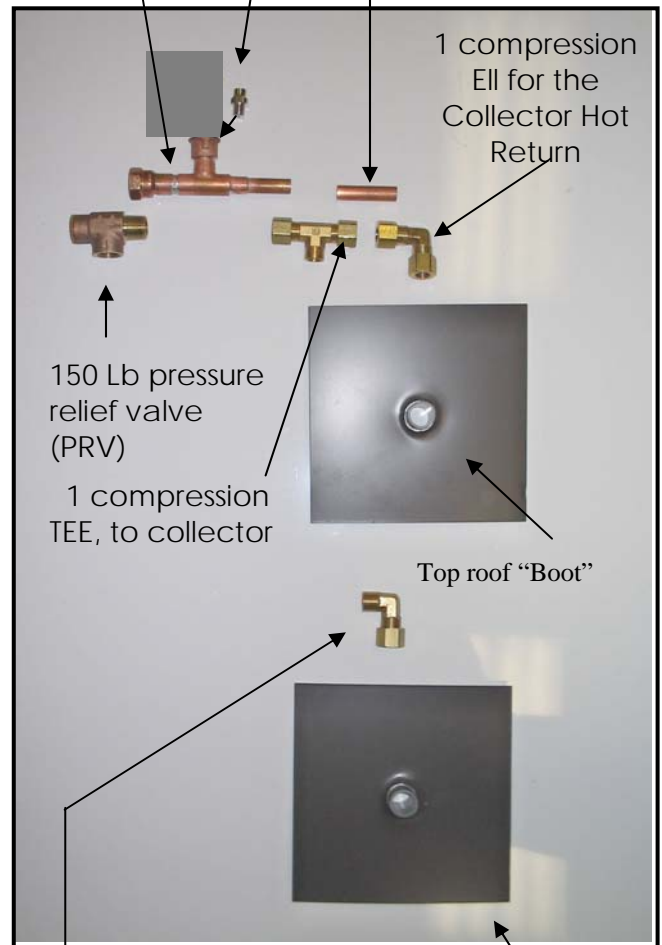

1 compression Ell for the feed.

Bottom Roof Boot"

SSC1 Side by Side Collector Installation Kit

IMPORTANT SSC1 TIP: Before installing the last Left collector, lift shingle for the flashing to go under. See: "Roof Boot" Flashing and Waterproofing Details.

The SSC1 is the same as SC01 with addition of a Tee and 2" stick of copper for 2nd collector.

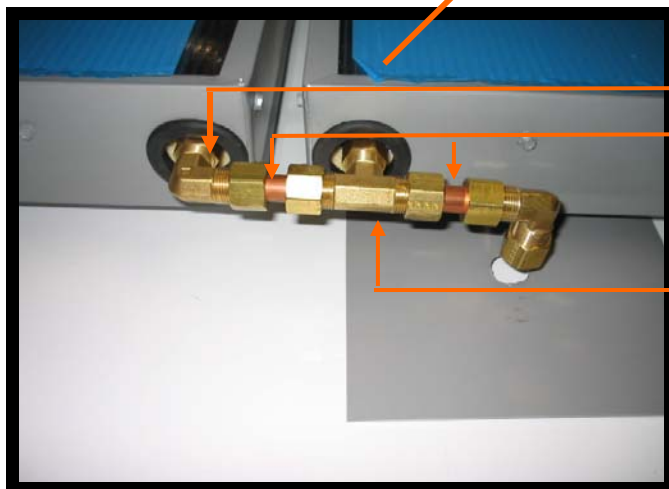
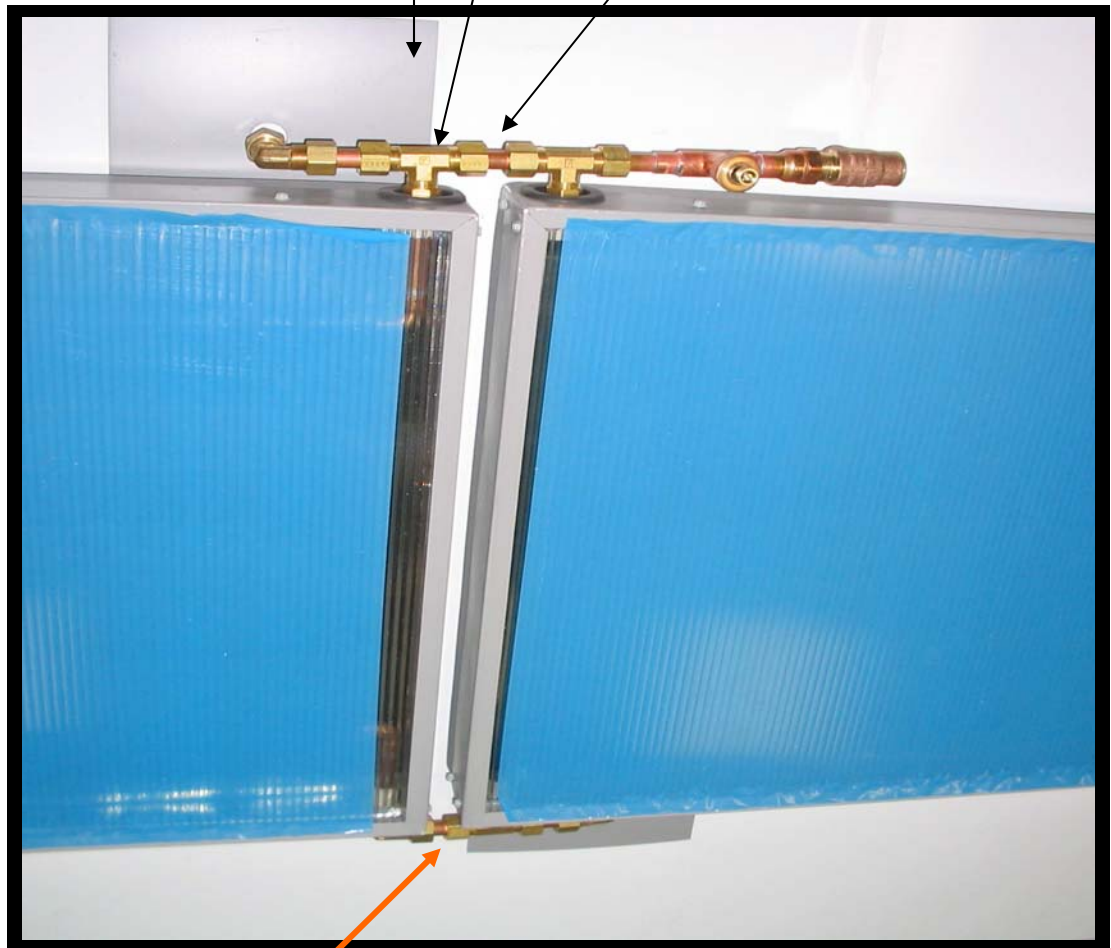

The SSC1 Feed has an additional Ell,
2 copper sticks
and a
Tee for the second collector.

7.0

DETERMINE THE BEST PIPE RUN

COORDINATE THE PIPE RUN WITH THE BEST SOUTH FACING COLLECTOR LOCATION FOR THE SHORTEST RUN.

IMPORTANT: SLOPE all lines to DRAIN! It is important that all pipes between the collectors maintain a 1/4" per foot drop to prevent traps and assure that all fluid drains when the drain valves are opened.

COMMON RUNS

In many one-story homes, the run is a simple matter of going up into the garage rafter area and to the roof or going through a wall or ceiling into the attic.

Common pipe runs to the basement include runs adjacent to air return chases, plumbing and vent lines and through closets. **In a two story house runs can be challenging; however, it is amazing how often a good solution is at hand.**

CHASES: Look for pipe, fireplace and duct chases with room around them. The pipes can often be dropped down next to a duct, especially in a one-story house, in just a few minutes.

CLOSETS: Sometimes the easiest way to run the pipes is through closets (look for "stacked" closets in a two-story house). Since 1/2" copper pipes are fairly flexible, drilling through even many shelves with an angle drill is easy as alignment does not have to be precise.

NOTE: Copper pipes get harder, even brittle with multiple bending; bend your pipe as little as possible for the easiest installation! Unroll the soft copper in smooth even strokes and be sure the connections for the collector are above the roofline so no water could get into the house if the connection leaks.

DRYWALL: It is sometimes necessary to cut drywall at the floor or ceiling level in order to cut the holes in a fire stop. Usually this hole can be made out of sight in a closet. After sealing the fire-stop, it may be desirable to make the remaining drywall removable by

putting a simple frame around it and placing it back in place with a few finish nails.

INFILTRATION AND FIRE STOPS: In all situations, remember that infiltration is one of the main sources of energy loss in a house. In no way should the installation of a solar system contribute to this loss! ALWAYS seal up any holes made in the house envelope especially in the attic and fire stops. Fire stops must be properly put back in place so their important function is preserved. Converting to copper pipe for two feet on either side of the firestop may be required in some areas.

STORAGE: You will need to purchase a 'Rheem Storage Tank, 80 Gallon with heat exchanger, Model # RH-81V080HE1.

You will need room to work around it and space for the solar hardware, usually a foot on the drain side of the heater is adequate. Install the tank connection components.

The Rheem Storage Tank is equipped with a top element only. To enhance your DHW efficiency, during the winter, first try using low flow showerheads and aerators and/or add a 220v switch to the top element. Another good plan is to use a 220v timer set to heat the water for two hours before you get up in the morning and for two hours before you get home from work.

Try turning the power off during sunny summer days. You should have ample Hot water with 2 panels for a family of 3 and with 3 panels for a family of 4 or 5 on clear summer days.

INSULATION: INSULATION OF EXPOSED COPPER PIPES IS NEEDED. A MINIMUM 1/2" R-2.6 (closed-cell insulation)* IS NEEDED AND 3/4" R-4.5 OR BETTER IS RECOMMENDED. Check your state and local codes to see if any greater thickness is required ESPECIALLY IF REBATES OR INCENTIVES ARE INVOLVED.

Determining The Pipe Run (birds eye view)

*Look for the following:

Note: ●● = solar pipe run

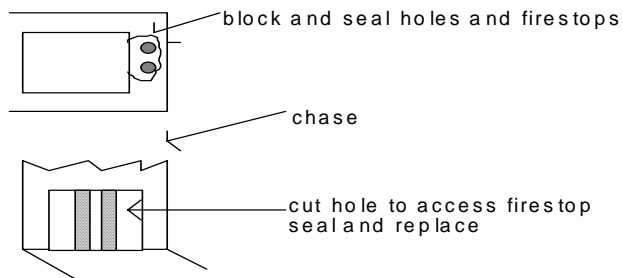
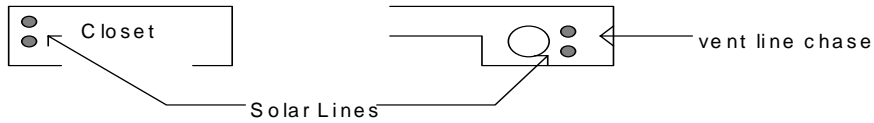
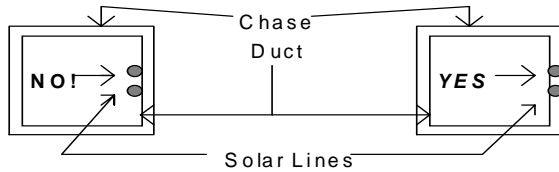
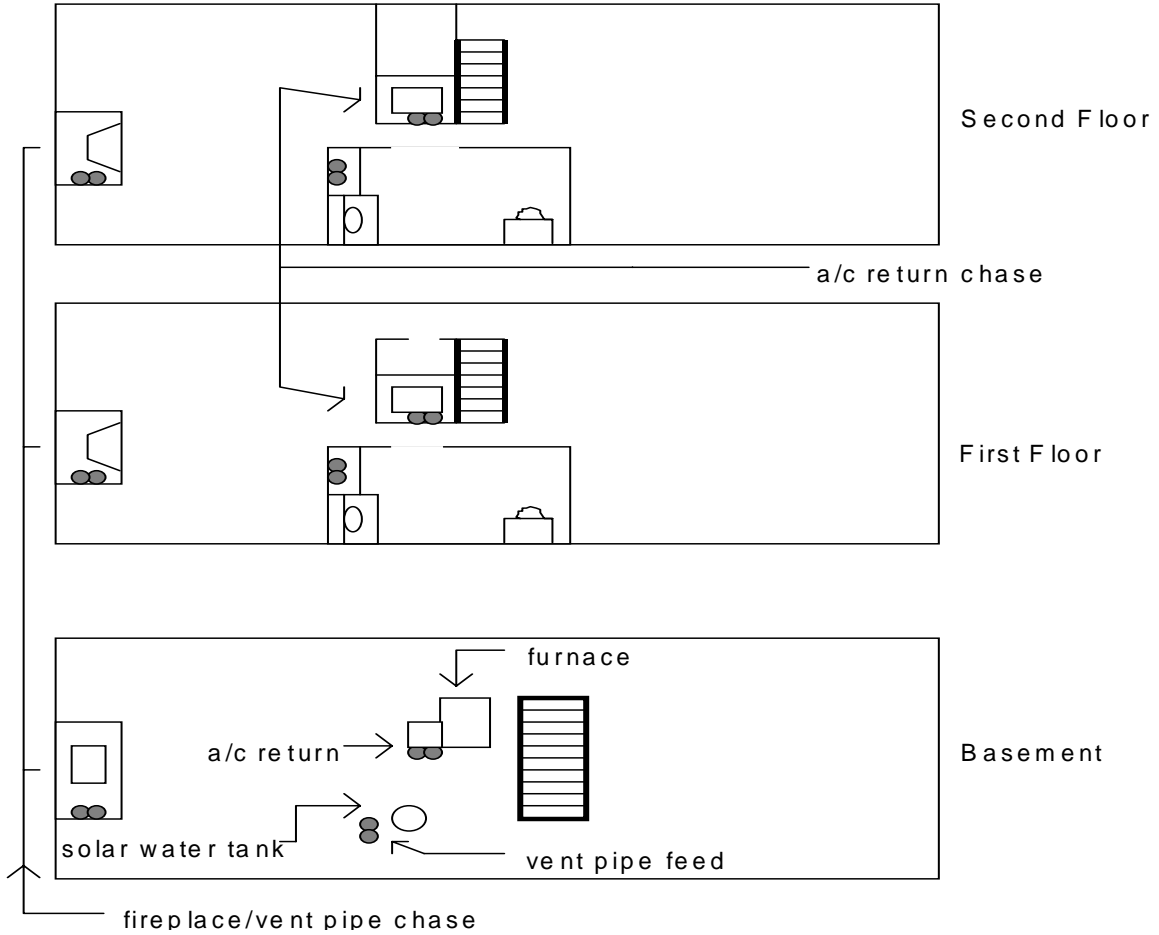

8.0

MAKING LINE CONNECTIONS

Line connections are easily accomplished using the supplied brass compression connectors.

When using compression connectors, be sure a small amount of tubing material is showing on the outside of the ring before tightening. See

Section 6.

Preparing the Collector

Pull the Absorber tubes fully out of the inlet and outlet holes. The absorber fins should line up side beside in the collector.

Collector Connections:

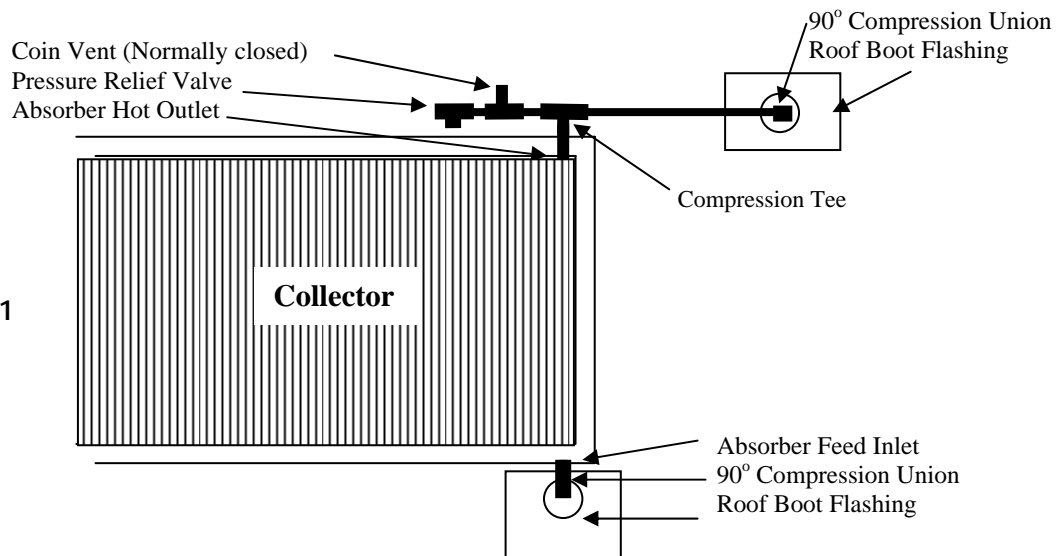

Diagram to the Left Applies only to SC01 Stacked Array Also see 6.0.

Collector Top Connection:

At the collector top connection, connect the supplied Tee compression fitting. Attach the pressure relief valve and air vent in the end of the Tee. Pressure relief should face down and the air vent up. The copper tubing may be installed into the Compression Tee, through the hole in the flashing later filled with caulk and insulated.

Tighten, but do not over tighten the connections. Be sure the line with the pressure relief and other valves on it are parallel with the roof. As mentioned, the pressure relief valve should be tightened so it faces down directly onto the roof, onto the supplied aluminum splash sheet, for safety. The coin vent must face directly up; it is normally closed tight and is used for manually releasing trapped air in the top of the system.

Bottom Connection of Collector: When the end of the union is flush with the edge of

the collector, alignment in the collector is correct.

Put in the 90° compression union at this point and drill a 1 ½" hole directly below it for the roof boot flashing to be installed.

Cut the shingle as needed and slide the roof boot flashing into place. The copper tubing will be installed into the union and the hole in the flashing later filled with caulk and insulated.

NOTE: The hole in the side of the collector will be covered with insulation as a final step. All insulation over fittings is done last, after the system is pressurized, to allow for checking for leaks and tightening the unions as needed.

Paint outside insulation with Latex paint or cover with aluminum tape to protect it from UV degradation.

The 50' roll of ½ OD copper tubing is easily unrolled and straitened by placing it on

the ground and unrolling it as you lightly step in the unrolled portion. It is sometimes easiest to feed the pipe down through the roof boot flashing and into the tank area.

A variety of techniques can be used depending on the situation such as needing to pull the pipe through an attic where it may need to come up from the bottom and be fed through the roof.



To prepare for the pipe runs, straighten the copper lines by putting a foot on the end and carefully unroll the tube and keep the line straight.

Carefully unroll the tubing through the roof boot into the attic. If available, have a partner guide the tubing to the tank being very careful not to kink the line. When working alone, it may be easier to unroll the tube in the attic or first floor and send the tubing up and through the roof boot from the attic.

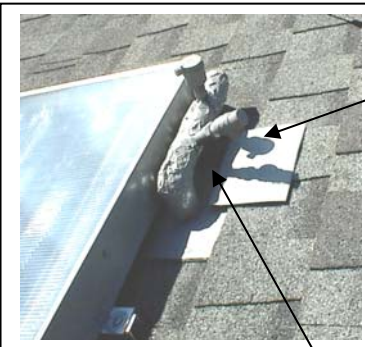
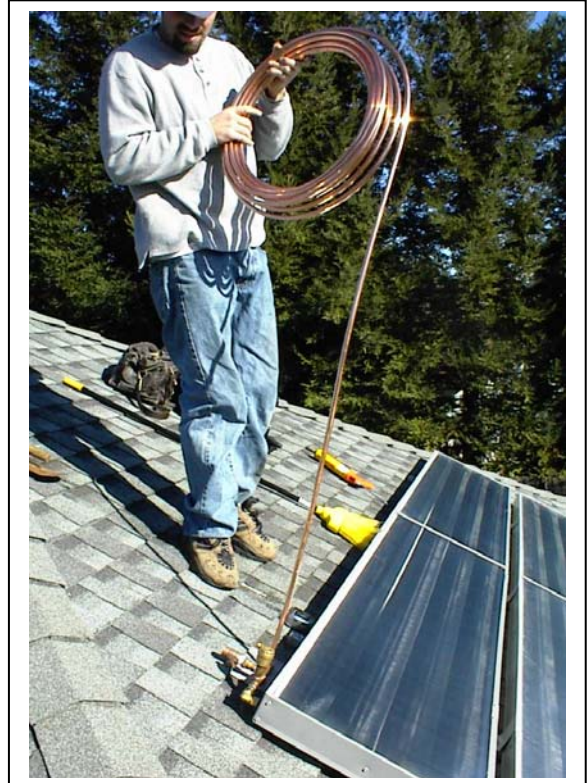

SRCC requires a splash plate under the pressure relief valve shown here glued to the shingles under the

Fully insulate all lines. Press about 1/2" of supplied high temperature insulation into grommet hole to fully seal. Covering the insulation with aluminum tape and painting is recommended. Be sure to overlap top over bottom like the shingles for good water shedding.



Important Note: Due to the extreme shortage of Small PV Modules, there will be variations of the actual PV modules and Wattages shipped.

9.0. CONTROL COMPONENT DETAILS

Photovoltaic (PV) panel: Place the PV panel on the same plane as the collector. If you have a tilt kit you may need to fabricate a tilt assembly for the PV panel. Attach the PV panel to the brackets with the supplied nuts and as shown. Screw brackets to roof with supplied long Tec Screws. Seal the roof penetrations with a quality sealant.

Wire nuts are supplied to connect the PV wire to the supplied wire, which then goes to the switch. We recommend going through the switch, breaking one wire for the switch and going out about 6" so the PV wire can be connected to the Pump wire with wire nuts. This way the Pump is easier to disconnect and service.

The PV brackets are bolted to the PV panel through existing holes in the frame of the PV panel with the supplied bolts, washers and nuts.

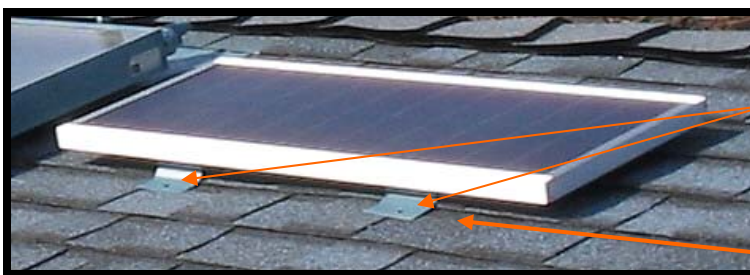
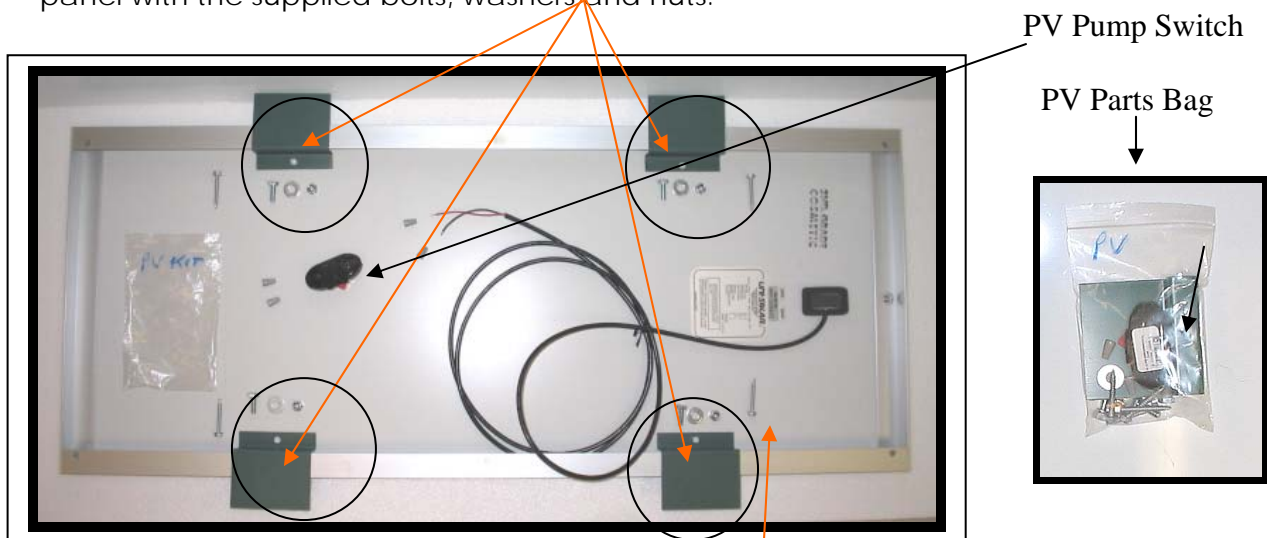

Long Tec Screws, go through the PV bracket and into Roof. Be sure to put a dab of calk under the bracket where the Tec screw will go through the roof.

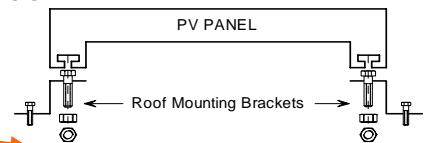

PV Wire: DO NOT ALLOW THE PV WIRE TO TOUCH THE PIPE! IT WILL MELT AND SHORT OUT! Drill a small hole under the panel, run the PV wire most of the way through it, seal with calk (lifting a shingle a little before drilling can help) and put PV panel in place over it.

Pump Connections: The PV panel wire is simply attached to a 14 to 18 gauge wire (supplied with full system) using wire nuts. It is then attached to the switch, which in turn is connected to the 12 Volt pump using wire nuts.

As mentioned, we recommend going through the switch, breaking one wire for the switch and going out about 6" so the PV wire can be connected to the Pump wire with wire nuts. This way the Pump is easier to disconnect and service. The on off switch is usually attached to an insulated pipe near the pump using tie wraps.

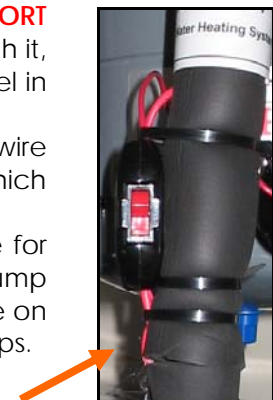

10.0.

TANK CONNECTIONS for SYSTEM 5

SolarRoofs.com

Rheem / Rudd / Richmond Model Number 81V080HE180 Gallon Heat Exchanger Tank Solar Component Installation

80 Gallon Heat Exchanger Storage Tank

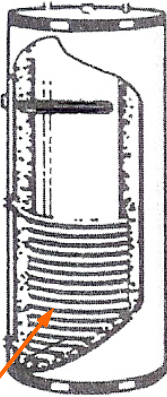

Heat Exchanger coil is wound around the tank as shown.

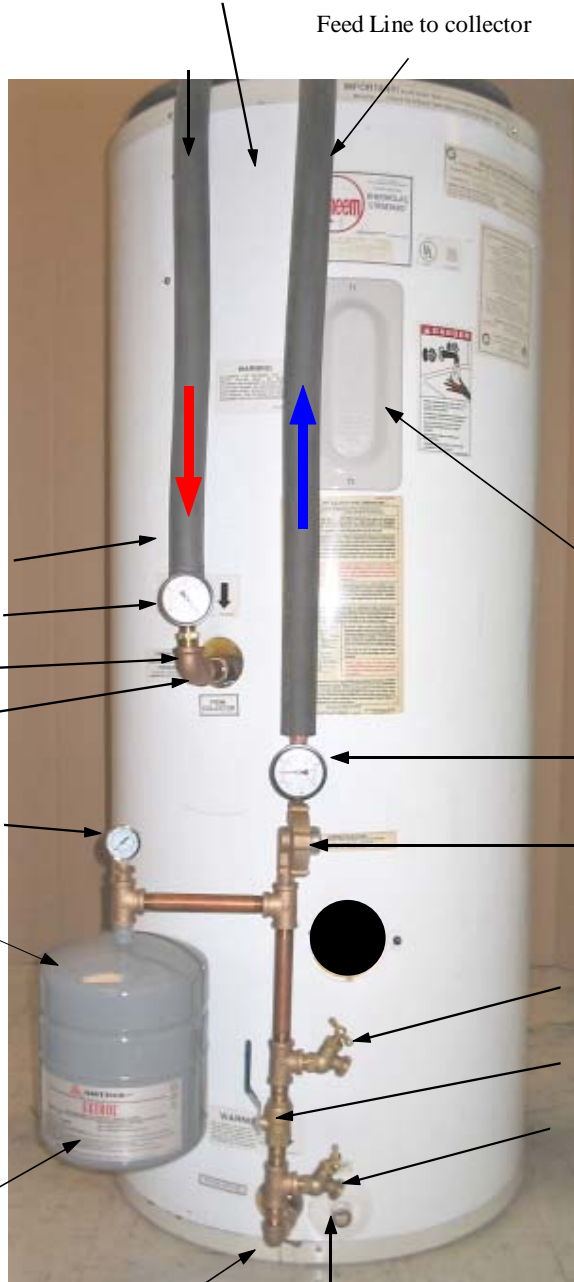

- Hot Return line from Collector
- "Hot In" Temperature Gauge
- "Floating Check Valve"
- Heat Exchanger In
- Solar Loop Pressure Gauge
- Expansion Tank

Before putting any fluid in the solar loop, Check to see that Expansion Tank is charged to 12 Lb. Charge glycol loop to 24, pounds, (about the maximum a drill pump will go to) or 10 to 12 pounds more than the Expansion tank was charged to. After charging, pressurize the loop by filling the Expansion tank with air to 50 pounds of pressure. This helps to prevent high temperature stagnation boiling.

Expansion tank factory set to 12 Lb.

Heat Exchanger Out

Tank Drain, can also be used to dilute Glycol to 50/50, as well as to flush and pressurize solar loop.

Be sure to connect a hose and open this valve and flush out the bottom of the tank at least every 6 months



If it is desirable to have the expansion tank and pump higher or above the tank, this can be accomplished by making an extension (like a long nipple) made from a 1/2" or 3/4" copper tube and two 3/4" copper by 1/2" male pipe thread (1/2" or 3/4" C x 1/2" MPT) adaptors on each end. This piece can then replace the 6" nipple between the Expansion tank Brass Tee and V1.

It does not matter if the pump is above or below the Expansion tank

Cover to 220 Volt Element

WARNING: Always turn off power at breaker and verify that power is off with a tester before doing any electrical work.

Return to Collector Temperature Gauge

Circulation Pump (Head only shown — pumps may vary)

Solar Loop Charging valve V1 used to fill system with water for flushing and Propylene Glycol for operation.

Isolation valve V3, close to charge system, open for operation.

Solar Loop Charging valve V2 used as out line to flush solar loop, as out for "Siphon Loop charging method," or to return Propylene Glycol to charging bucket with preferred pump charging method.

NOTE: For The Two Tank System 5 Diagram, See Large Diagram In Section 2.

IMPORTANT: Be sure floating ball goes inside the 1/2" x 3/4" nipple adaptor as shown and that the tank 3/4" brass nipple arrows point towards the tank with the ball block on the outside.

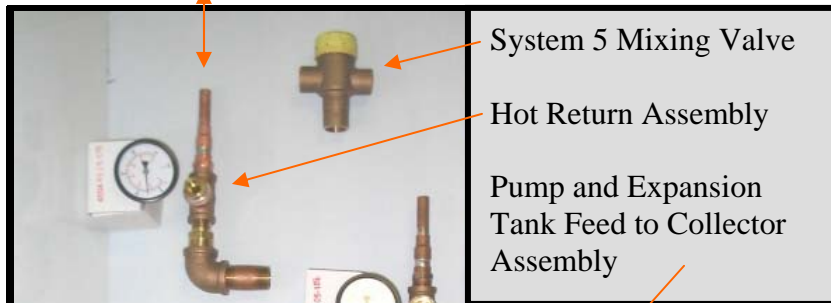
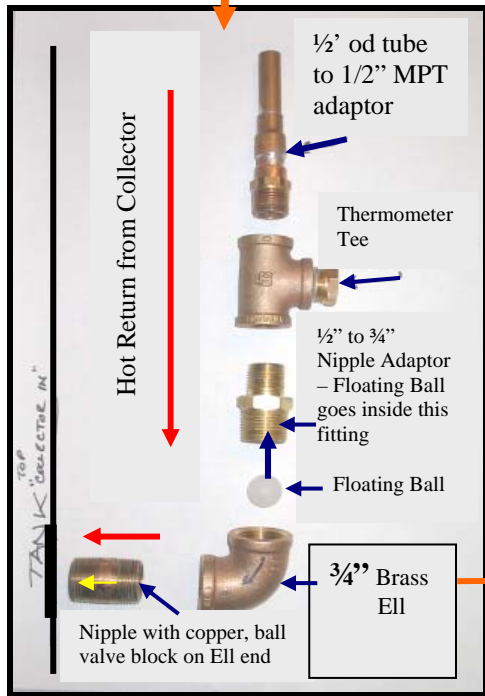

Charging Valve Assembly



Charging Valve Assembly

1/2" X 3/4" Brass adaptor to tank nipple



Installing the Heat Exchanger Connections

Refer to Above For Individual Components.

- 1) The threaded brass fittings are installed using pipe dope.
- 2) **Heat Exchanger IN (Hot Return):** Starting at the bottom with the 3/4" brass nipple, connect and tighten the Hot Return Brass Fittings (with the temperature gauge and check valve) to the TOP Heat Exchanger fitting as shown. Carefully follow the diagram at the top left of the previous page for installing the ball valve. Be sure the check valves brass nipple has the stop facing the outside of the tank so the floating ball does not go inside the nipple.
- 3) **Heat Exchanger OUT (Collector Feed):** Starting at the bottom with the 3/4" brass nipple, connect and tighten the nipple, attach the 3/4" to 1/2" brass adaptor, 1/2" street 90, charging valves, 6" nipple, expansion tank and pressure gauge assembly, pump and temperature gauge as shown. Connect the bronze Pump housing with the arrow up.
- 4) If using non split insulation, put insulation on the feed and return lines prior to connecting lines to tank.
- 5) Connect the Collector feed line to the tank's pump feed line using the supplied 1/2" compression unions.
- 6) Connect the Collector Hot Return Line to the short Hot Return Tank Fitting.
- 7) Connect the tank hot and cold lines and Mixing Valves per the diagram below.
- 8) Charge the system by following one of the 2 procedures in Section 11.0 below.
- 9) Insulate all water lines including the last 5' of cold water line as accessible with R-2.6 or greater insulation.
- 10) The PV pump is simply connected to the switch, which is then connected to the PV panel wires: see 9.0.

Before insulating the lines, pressurize the solar loop with water and thoroughly test for leaks.

See following sheet for instructions on pressure testing and charging the Glycol Loop.

Mixing Valve Installation

(Only the mixing valve is supplied with the kit – the picture below is supplied for illustration)

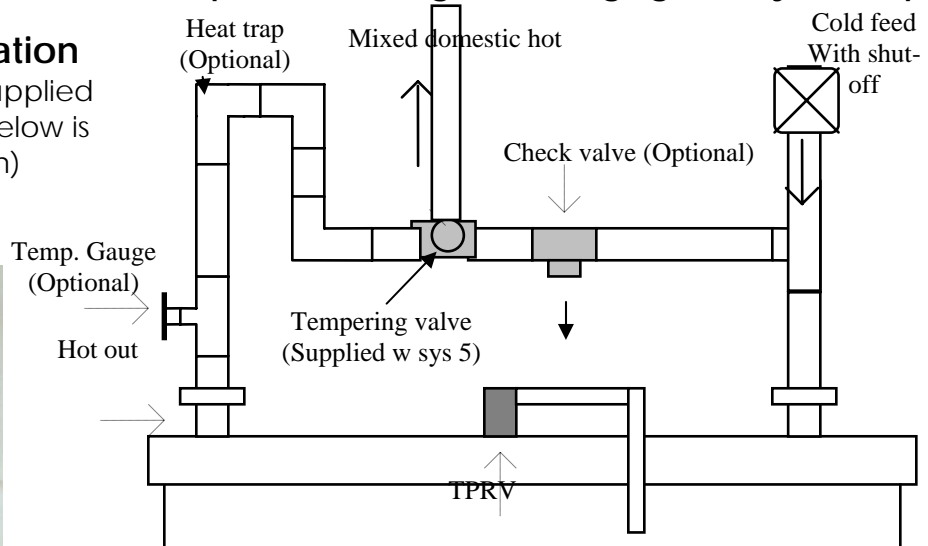

NOTE: The supplied system 5 mixing valve (which automatically allows cold water to mix into the hot water) is required for SRCC OG300 and can be installed by your plumber. There are many ways to install the mixing valve as long as the ports are correct. The check valve is optional.

IMPORTANT WARNING: TO AVOID DAMAGE, ALWAYS REMOVE THE INNER PARTS TO THE MIXING VALVE BEFORE SOLDERING.

Mount the sheet titled **"Important Warnings and Instructions"** onto the front of the tank, Cut out, peel the backing off and place the supplied labels with their corresponding components.

11.0.

Charging the Solar Loop with Propylene Glycol

Items needed: 2 - 5 gallon buckets, 2 or 3 gallons of glycol, charging pump, 3 laundry hoses.



1. You will need 2 or 3 gallons of Propylene Glycol. Sierra brand or equal, can be picked up at most Auto Parts Stores and other brands are available at Camping centers where it is used to freeze protect plumbing.

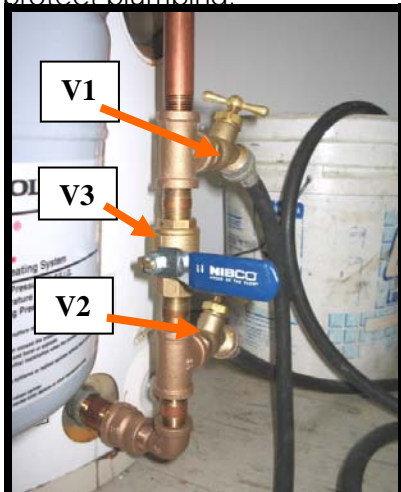

4. The first step (not shown) is to hook a laundry hose from the bottom of the storage tank to the top charging port hose bib **V1**, connect a hose to the bottom hose bib **V2**, close the ball valve **V3** between, and run full pressure water through the system to flush any debris out of the solar loop. Close V2, build to 40 pounds, close the V1, and check for leaks at all connections.

Caution: In cold weather, only do this if Glycol is immediately going to be put in system!



2. Check the Pressure in the Expansion tank to be sure it is **12 -14 pounds (lb)**, of not, fill to 14 lb. (the system will be charged to 24 – 26 lb) and topped off at 48 to 50 lb. (see 7.)



5. With 3 laundry hoses, connect V1 to the pump outlet, the second hose from the glycol bucket to the pump inlet and the third hose from V2 into the 2nd bucket as shown. Fill the glycol bucket with 4 gallons 50/50 water / glycol mixture. V3 must be closed. Open V1 and let water out to clear all air out of the hoses into the glycol bucket. This also primes the pump if needed. Turn on the pump, holding onto the hose in the 2nd bucket (so it doesn't fly around!) open V2. Watch for either the glycol to come out of V2 hose or for the glycol to be within 3 inches of the bottom of the glycol bucket and quickly switch the V2 hose into the glycol bucket.

IT IS VERY IMPORTANT THAT NO AIR GET INTO THE SOLAR LOOP!

If needed, add more glycol to maintain a good mixture.



3. You can use a low cost hand drill pump like the above. Be sure to use it with a high speed drill, usually a 110 Volt drill is best to get to 24 pounds of pressure. A more powerful 110 Volt pump like the one shown in the pictures below is recommended.



6. We want to be sure all air is out of the solar loop so when you switch the V2 hose into the Glycol bucket, the "Purge Cycle" is started. Run the pump for about 5 minutes to be sure all air is clear from the solar loop. Close V2 and build pressure to about 24 lb. (if the pump is not strong enough, use a laundry hose purged of air to build pressure in the solar loop to 24 lb.)

We want about 10 lb more pressure in the loop than the Expansion tank is set for. Close V1 and open V3. Run the solar pump to see if hot glycol is coming down the lines, **CAUTION, it could be VERY HOT!**

7. Finally, pressurize Expansion tank to 50 lb. of pressure to increase the boiling point of the system (your solar loop pressure gauge will also read 50 lb.) – Your Loop is Charged!

Charging the “Fireball 2001” Rheem HE System Non-Toxic Propylene Glycol Solar Loop*

NOTE: A CHARGING PUMP IS RECOMMENDED, use the following method if one is not available and only when freezing weather is not a threat.

*Use non-toxic Propylene Glycol only, never use or mix with Ethylene Glycol (Antifreeze)

NOTE: You will need 2 Laundry hoses (these can be "borrowed" from the washing machine).

Check so see that the pressure in the Expansion Tank is at 40lb, add pressure if needed.

**Charging the solar loop is done through "Charging Valves", V1 and V2 using V3 to control flow:
This simple procedure uses gravity to fill (charge) the solar loop with Glycol.**

V1, the Fill Valve is where water enters to fill the solar loop and “flush” the system after which the glycol mixture enters by siphon from the "charging bucket" to fill the solar loop.

V3 acts as a block to force water and glycol up to the collector, through the entire loop and out V2. When "Flushing" or "Charging" V3 is to be Closed, in operation V3 is to be Open.

V2, is called the Purge Valve because, when open, it allows water used to flush the system to exit and purge air from the solar loop carrying any contaminants with it. When closed, after flushing and no more air is in the loop, the system is pressurized through V1 allowing the loop fittings to be checked for any leaks prior to charging the loop with glycol. Glycol can then be charged into the loop using a charging pump or the siphon method described here.

SIPHON LOOP CHARGING TECHNIQUE (or use charging pump if available)

Connect a laundry hose to the Tank Drain and connect it to V1. Close V3 and fill the solar loop with water through V1 and allow water to flow out a hose connected to V2 to flush the solar loop. Close V2, allow pressure to build to 48 - 50 pounds, close V1 and check the system for leaks. **Keeping the loop full of water**, disconnect the V1 hose from the Tank Drain and insert it into the bottom of a 5 gallon bucket with at least two gallons of a 50/50 mix of glycol and water. **Fill the hose with water so no air is in it.** Elevate the bucket as high as possible. **It is important not to get any air in the loop.**

Open V2, have its hose drain to as low a point as possible then open V1. Glycol should then flow into the loop. **Be sure to not let any air into the system by preventing the gallon container of glycol from fully emptying, add water as needed.** When Glycol starts to flow out V2, Close V2 then V1.

Reconnect the V1 laundry hose to the Tank Drain. Loosen the connection at V1. **With V1 closed, slowly add water until all air is out of the laundry hose, tighten the hose onto V1 and with water still slowly flowing open V1.**

Add water through V1 until the pressure gauge reads **50 - 52 pounds**, close V1. Be sure air vent cap at the top of the solar loop is loose. Open V3 valve so solar loop is open to circulate.

Turn the pump on and check for circulation. If the sun is out, the solar return line should get hot. If the pump sounds loud, air is probably in the system and it is “cavitating”. “Bump” the pump by turning it off and on until the air leaves the pump and goes out the air vent. Your system is “Charged.”

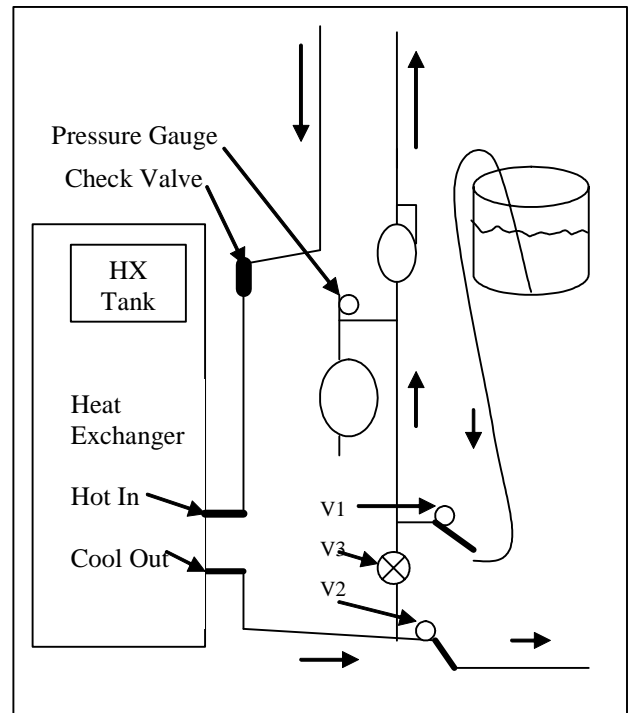

We Hope Your installation Went Smoothly!!

**PLEASE CALL Power Partners WITH
QUESTIONS OR COMMENTS:**

(706) 548-3121 1-800-545-3121

Thank You and Now Enjoy the Savings!

12.0.

QUESTIONS AND ANSWERS:

HOW DO I GET THE MOST EFFICIENCY FROM MY SOLAR WATER HEATER?

An easy method to increase storage efficiency is to have a 220-volt timer installed by an electrician.

It will activate the element for 3 hours in the early morning (say from 5AM to 8AM) for showers etc. and on again in the early evening (say from 4PM to 10PM) for evening use if solar gain hasn't been good that day.

This increases the solar efficiency by not allowing the element to come on during hours of solar gain as well as keeping it off during non-use nighttime hours.

Ideally, it is most efficient to completely turn off the electricity in sunny weather.

WHAT ABOUT FREEZE PROTECTION?

The Power Partners closed loop Propylene Glycol Antifreeze heat exchange system's collector as well as feed and return lines will not be damaged by (ambient) hard freeze temperatures as low as -54 degrees F below zero with a 60/40 mixture of propylene glycol/water.

The solar storage tank must be kept in an area above 32 degrees F.

WHAT ABOUT HIGH TEMPERATURES?

The 2001 collector will not be damaged by stagnation in ambient temperatures as high as 120 F.

12.1.

SRCC and FSEC Collector Certifications And SRCC System 5 Certifications

SOLAR COLLECTOR CERTIFICATION

Florida Solar Energy Center®
1679 Clearlake Road
Cocoa, Florida 32922-5703



FSEC 00325C
MANUFACTURED BY:
Power Partners, Inc.
200 Newton Bridge Road
Athens, Georgia 30607

MODEL #
Skyline 10-01

SERIAL #

GROSS COLLECTOR AREA: 0.929 m² (10.00 ft²)
COVER PLATE AREA: 0.870 m² (9.37 ft²)
COLLECTOR LENGTH: 1.829 m (6.00 ft)
COLLECTOR WIDTH: 0.508 m (1.67 ft)
COLLECTOR WEIGHT: 8.6 kg (19.0 lb)
FLUID CAPACITY: 0.8 L (0.2 gal)
REC. FLOW RATE: 25 Liquid mL/s (0.4 gpm)
TEST PRESSURE: 1103 kPa gauge (160 psig)
THERMAL PERFORMANCE EFFICIENCY (ASHRAE 93-86)
Y INTERCEPT: 61.4
SLOPE: $379 \frac{\text{Watts}}{\text{m}^2 \cdot ^\circ\text{C}}$ $\left(67 \frac{\text{Btu}}{\text{ft}^2 \cdot \text{hr} \cdot ^\circ\text{F}} \right)$
INCIDENT ANGLE MODIFIER, AXIS 1: 0.21 AXIS 2: N/A

has been tested for thermal performance and meets the minimum standards established by the Florida Solar Energy Center as directed by Section 377.705 Florida Statutes.

THERMAL PERFORMANCE RATINGS*

Low Temp. (35°C, 95°F)	9,600 kJ/day	9,100 Btu/day
Intermediate Temp. (50°C, 122°F)	7,900 kJ/day	7,500 Btu/day
High Temp. (100°C, 212°F)	3,500 kJ/day	3,400 Btu/day

*Based on an assumed standard day for Florida.

	<p>This product certified by the Solar Rating and Certification Corporation c/o FSEC, 1679 Clearlake Road Cocoa, FL 32922 (321)638-1537 www.solar-rating.org SRCC Document OG-100</p>	<p>Power Partners, Inc. 200 Newton Bridge Road Athens, GA 30607 Model No.: 20-10 Gross Area: 1.87 m² (20.07 ft²) Serial Number:</p>	<p>Clear Day Rating in Category C 18 MJ/day 17 kBtu/day</p>
--	---	--	--

	<p>This product certified by the Solar Rating and Certification Corporation c/o FSEC, 1679 Clearlake Road Cocoa, FL 32922 (321)638-1537 www.solar-rating.org SRCC Document OG-100</p>	<p>Power Partners, Inc. 200 Newton Bridge Road Athens, GA 30607 Model No.: 10-10 Gross Area: 0.93 m² (10.04 ft²) Serial Number:</p>	<p>Clear Day Rating in Category C 9 MJ/day 8 kBtu/day</p>
--	---	--	--



This product certified by:
 Solar Rating and
 Certification Corporation
 1679 Clearlake Road
 Cocoa, FL 32922
 (321)638-1537

Power Partners, Inc.
 200 Newton Bridge Road
 Athens, GA 30607

System Serial No. _____

SRCC Document OG-300

www.solar-rating.org

System Model:	SRCC Certification Number:	Solar Energy Factor:
<input type="checkbox"/> 200131C50	300-2008-002A	1.5
<input type="checkbox"/> 200132C50	300-2008-002B	2.2
<input type="checkbox"/> 200133C80	300-2008-002C	3.2
<input type="checkbox"/> 200133C50	300-2008-002D	3.4
<input type="checkbox"/> 200132C80	300-2008-002F	2.1
<input type="checkbox"/> 100133C50	300-2008-002G	1.8
<input type="checkbox"/> 200152C80EX	300-2008-003A	1.7
<input type="checkbox"/> 200153C80EX	300-2008-003B	2.1
<input type="checkbox"/> 200154C80EX	300-2008-003C	2.6
<input type="checkbox"/> 200132C502TE	300-2008-004A	1.8
<input type="checkbox"/> 200152C80EX2TE	300-2008-005A	1.6
<input type="checkbox"/> 200153C80EX2TE	300-2008-005B	1.9
<input type="checkbox"/> 200132C50T20E	300-2008-006A	1.8